

REVISIONS				
ZONE	LTR	DESCRIPTION	DATE	APPROVED
1C	A	7/8 DIMENSION WAS 11/16		

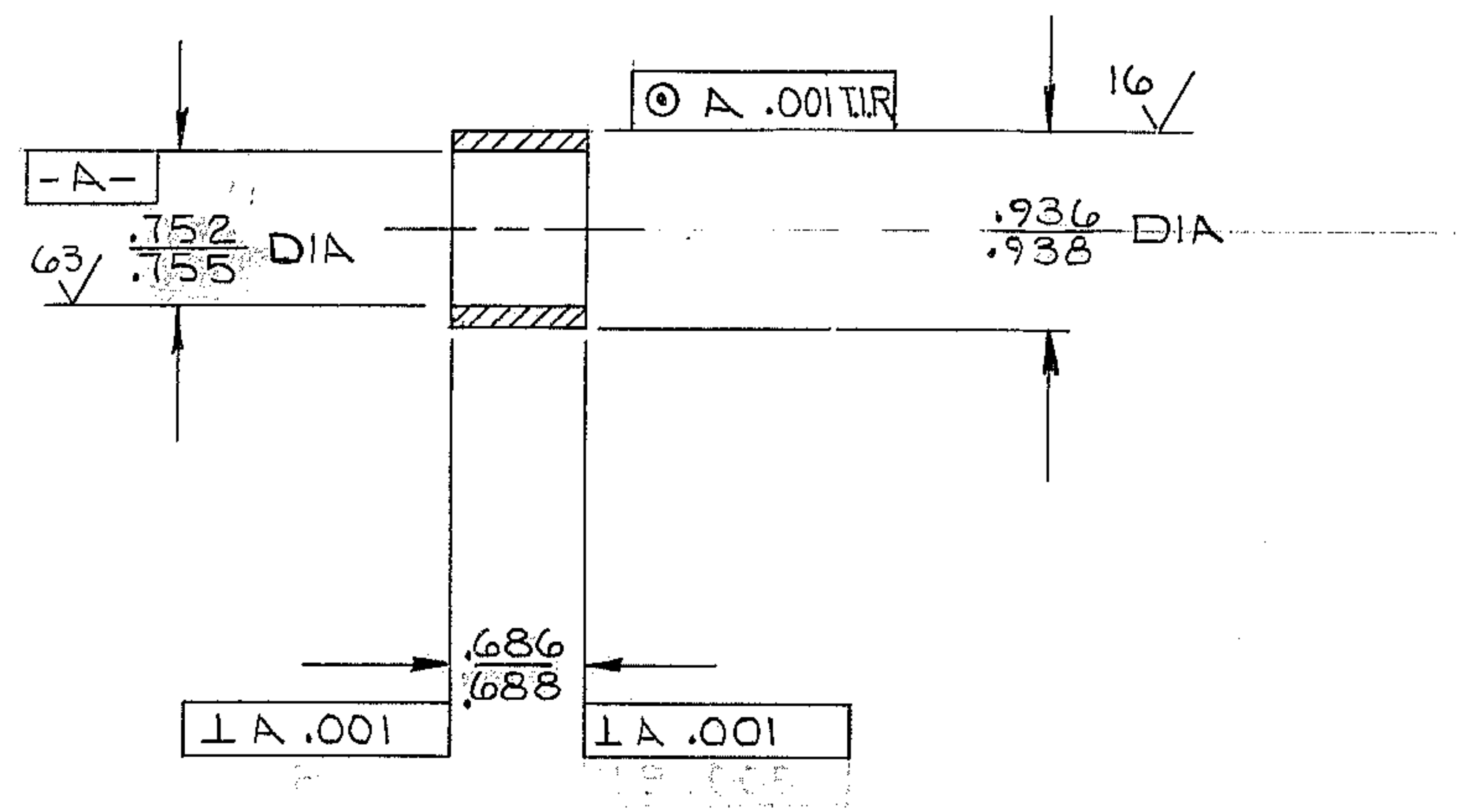

NOTES:
 1 DIMENSIONS ARE IN INCHES.
 2 MATL: STL BAR AISI C1018 DIA X 1 7/8" OR EQUIV.
 3 TAG WITH PART NO. 2150.240B 030.

WESTERN GEAR CORPORATION
 CONSTRUCTION PROJECTS
 DEPARTMENT
 APPROVED FOR
 PROCUREMENT
 GR. DATE SEP 18 1968

REF. FILE 1167

NEXT ASSY: 2150.240E 002 (W.G.N 102 993)

LIMITS ON MACHINED DIMENSIONS EXCEPT AS NOTED ANGULAR ± 1° 0' LINEAR .X = ± .1 .XX = ± .03 .XXX = ± .010 FRACTIONAL ± 1/32 BREAK ALL SHARP EDGES	150 IN. STELLAR TELESCOPE MTG	western GEAR CORPORATION HEAVY MACHINERY DIVISION EVERETT, WASHINGTON		
	DRAWN R. ORR	SLEEVE, SEAL CASSEGRAIN RAMP ASSY		
CHECK R. NIEVES	ENGR	W.G.C 112512	SIZE B	CODE IDENT NO. 2150.240B030
APPROVED			SCALE 1/1	WT. LB SHEET 1 OF 1