

REVISIONS				
ZONE	LTR	DESCRIPTION	DATE	APPROVED
4C	A	.6693 DIMENSION WAS .6695	9/17/68	
1A	B	WORM SHAFT WAS L/S	4-11-73	LDS

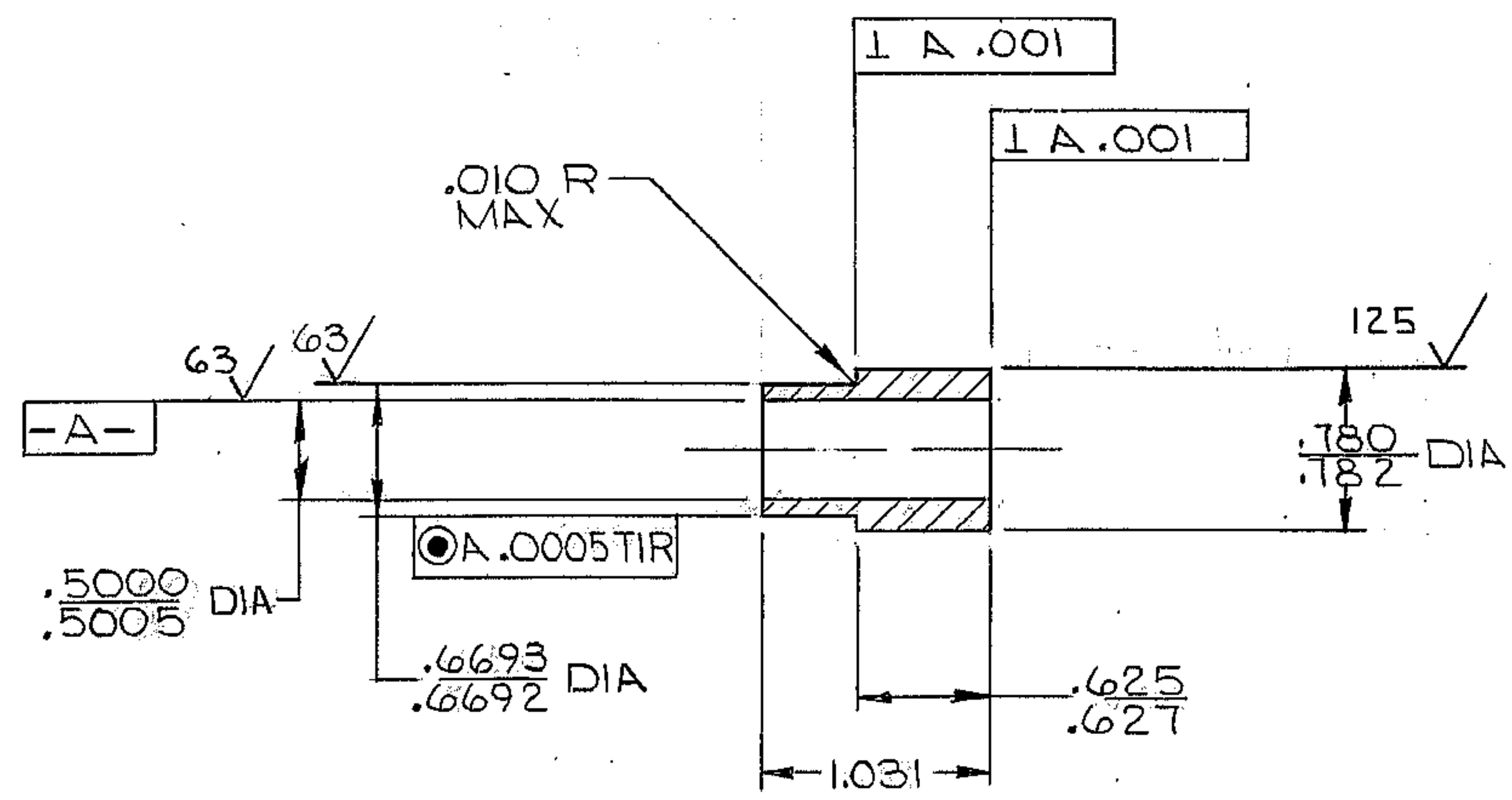

NOTES:  
 1 DIMENSIONS ARE IN INCHES.  
 2 MATL: 5TL BAR AISI C1018 7/8 DIA x 1/8 LG OR EQUIV.  
 3 TAG WITH PART NO. 2150.240B028.

REF. FILE 1167

WESTERN GEAR CORPORATION  
 CONSTRUCTION PROJECTS  
 DEPARTMENT  
 APPROVED FOR  
 PROCUREMENT  
 G.R. DATE SEP 18 1968

NEXT ASSY: 2150.240E002 (W.G.N 102993)

LIMITS ON MACHINED DIMENSIONS EXCEPT AS NOTED ANGULAR ± 1° 0' LINEAR .X = ± .1 .XX = ± .03 .XXX = ± .010 FRACTIONAL ± 1/32  BREAK ALL SHARP EDGES	150 IN. STELLAR TELESCOPE MTG	Western GEAR CORPORATION HEAVY MACHINERY DIVISION EVERETT, WASHINGTON		
	DRAWN R. ORR CHECK R. NIEVES ENGR	SLEEVE, WORM SHAFT, CASSEGRAIN RAMP ASSY		
W.G.C 112514	SIZE B	CODE IDENT NO. 16603	2150.240B028	REV B
APPROVED	SCALE 1/2	WT.	LB	SHEET 1 OF 1