

5

4

3

2

1

REVISIONS				
ZONE	LTR	DESCRIPTION	DATE	APPROVED
B5	A	NOTE 1 WAS - BASED ON UJNS N°1010 JOINTS.	9-17-68	
B2	A	BOSTON EUB MOTOR WAS NEMA 48C MOTOR.		
C4/C2	A	2 1/2 DIMENSION DELETED.		
3C	A	12 3/4 / 15 5/8 WAS 7 3/4 / 10 5/8.		
2C	B	5/8 BORE x 3/16 x 3/32 KEYWAY WAS 1/2 BORE	12-10-68	
1B	C	GUB MOTOR WAS EUB	2-7-69	
	C	NOTE #4 WAS 1/3 H.P. & 15 DIM WAS 15 5/8	2-7-69	
	D	R1032 WAS R1022	4/11/73	LDS

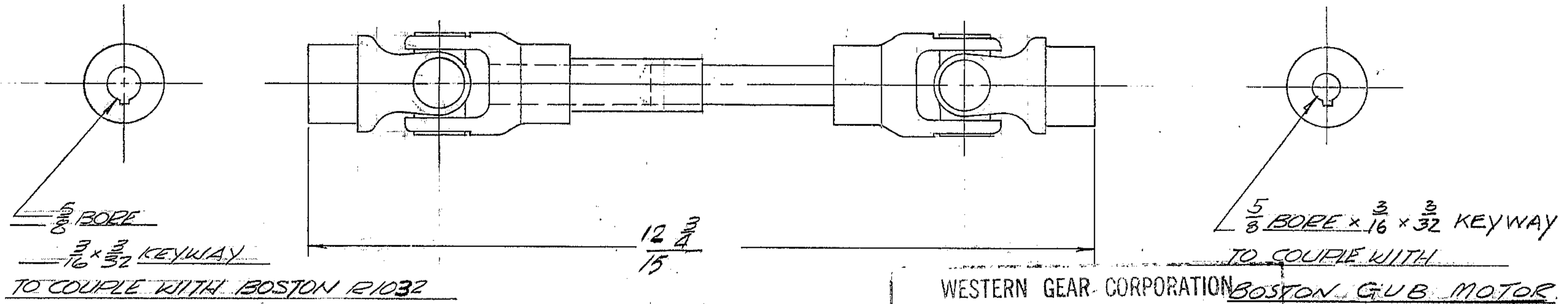

NOTES: -

1. MAY BE PURCHASED FROM BOSTON GEAR.
2. MAX. OPERATING ANGLE 21°
3. SPEED: 1750 R.P.M.
4. HORSEPOWER 3/4

WESTERN GEAR CORPORATION
 CONSTRUCTION PROJECTS
 DEPARTMENT
 APPROVED FOR
 PROCUREMENT
 GR DATE SEP 18 1968

REF. FILE 1167

NEXT ASSY: 2150.240E 002 (W.G.N 102 993)

LIMITS ON MACHINED DIMENSIONS EXCEPT AS NOTED ANGULAR ± 1° 0' LINEAR .X = ± .1 .XX = ± .03 .XXX = ± .010 FRACTIONAL ± 1/32 BREAK ALL SHARP EDGES	150 IN. STELLAR TELESCOPE M.T.G.	WESTERN GEAR CORPORATION HEAVY MACHINERY DIVISION EVERETT, WASHINGTON		
	DRAWN <i>[Signature]</i> CHECK ENGR	TELESCOPING DRIVE SHAFT ASSY CASSEGRAIN RAMP ASSEMBLY		REV D
	W.G.C 112506	SIZE B CODE IDENT NO. 16603	2150.240B017	
	APPROVED	SCALE 1/2" = 1" WT. LB SHEET 1 OF 1		