

REVISIONS			
ZONE	LTR	DESCRIPTION	DATE
A		REVISED PER AREA APPROV. PRINT	8-14-63
B		REVISED PER AREA APPROV. PRINT	8-15-63
C		REVISED PER AREA APPROV. PRINT	8-26-63
D-3		DELETED FAB. DIM. FROM 3/4" DIA.	9/1/71
D-3		DELETED FIN. FROM 1/8" DIA.	-J.W.

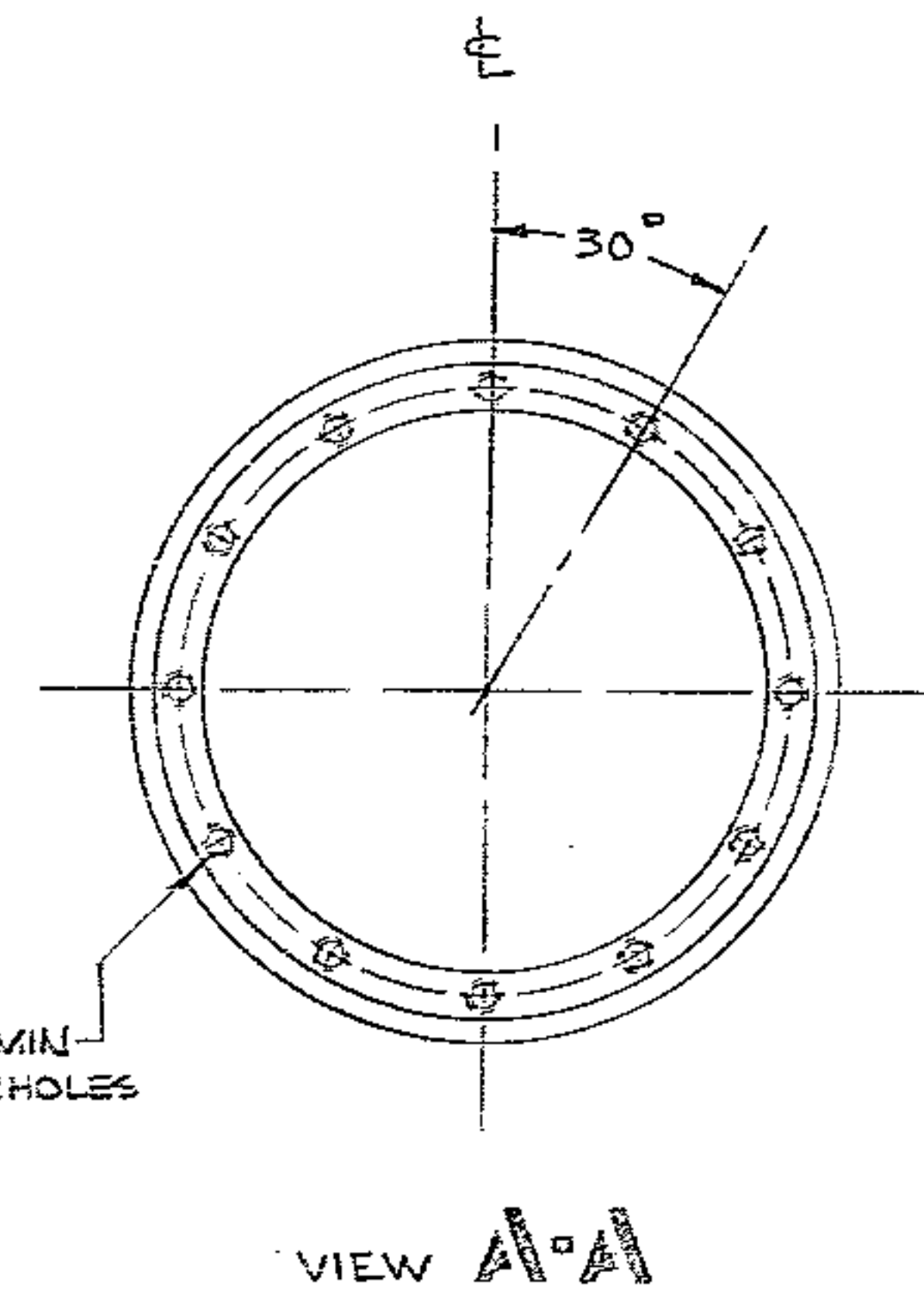

$\frac{3}{16}$ DRILL 12 PLACES
 EQ. SPACED ON A
 14.187 B.C.
 $\phi .020$ DIA

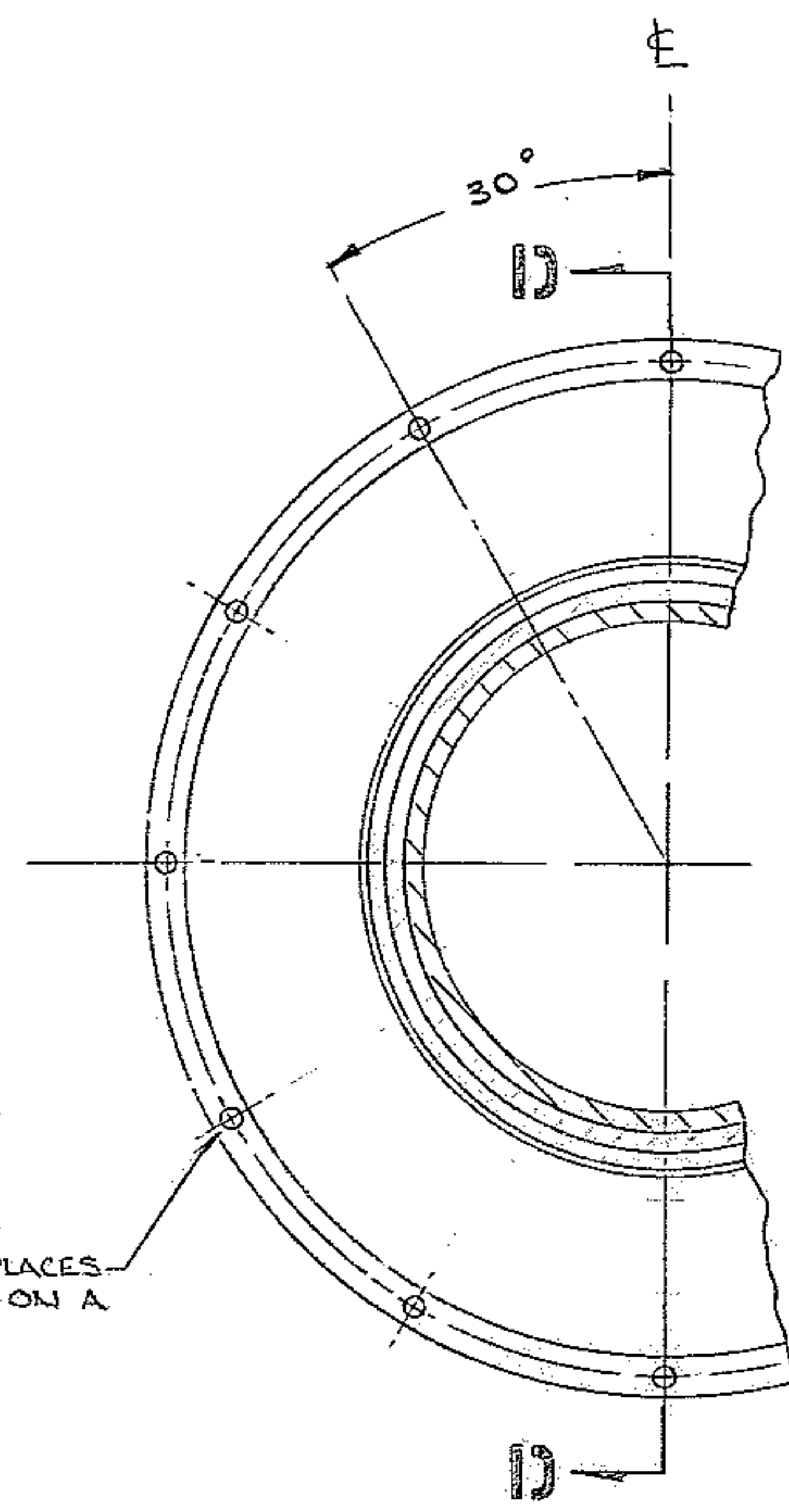

SECTION B-B

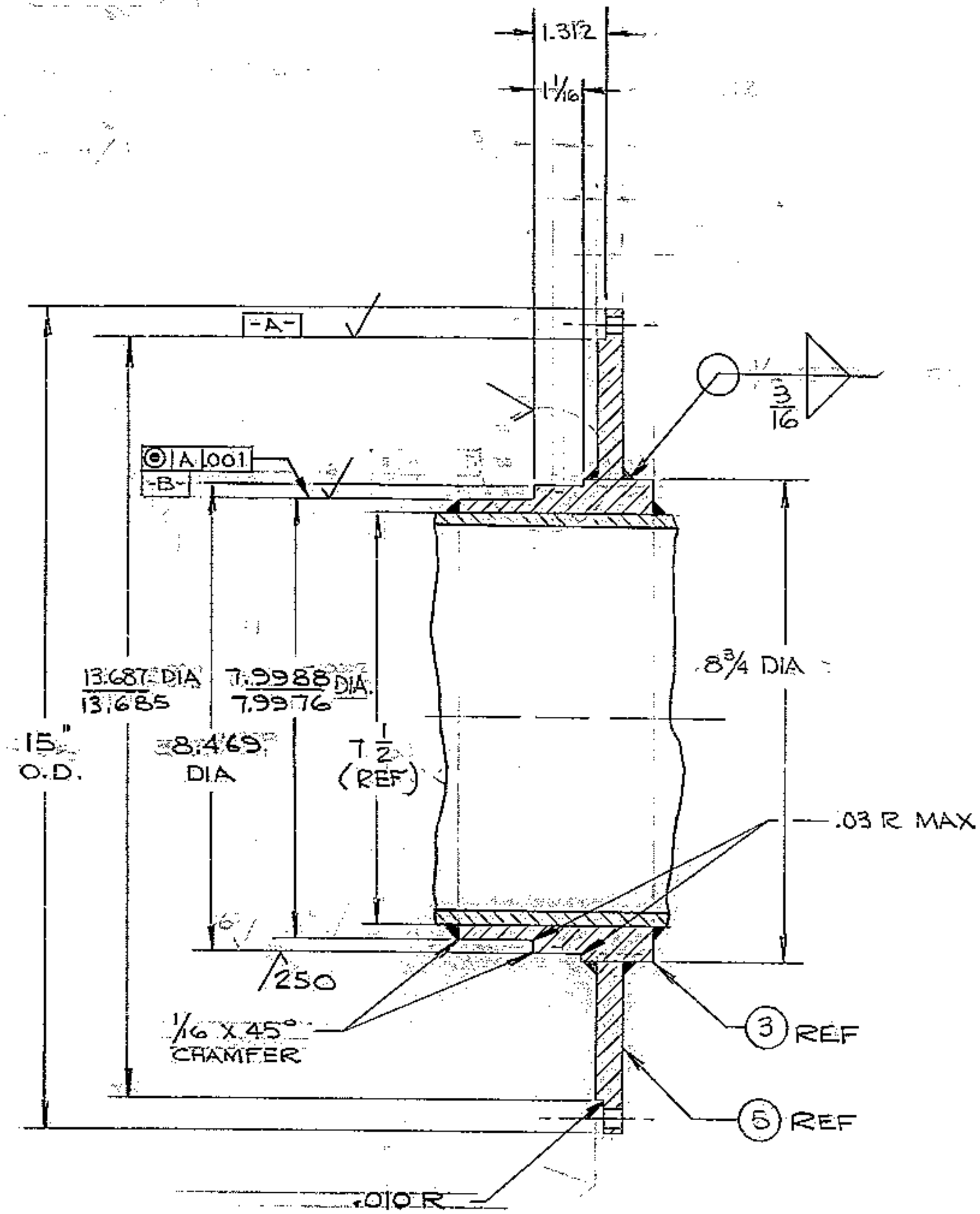

SECTION D-D

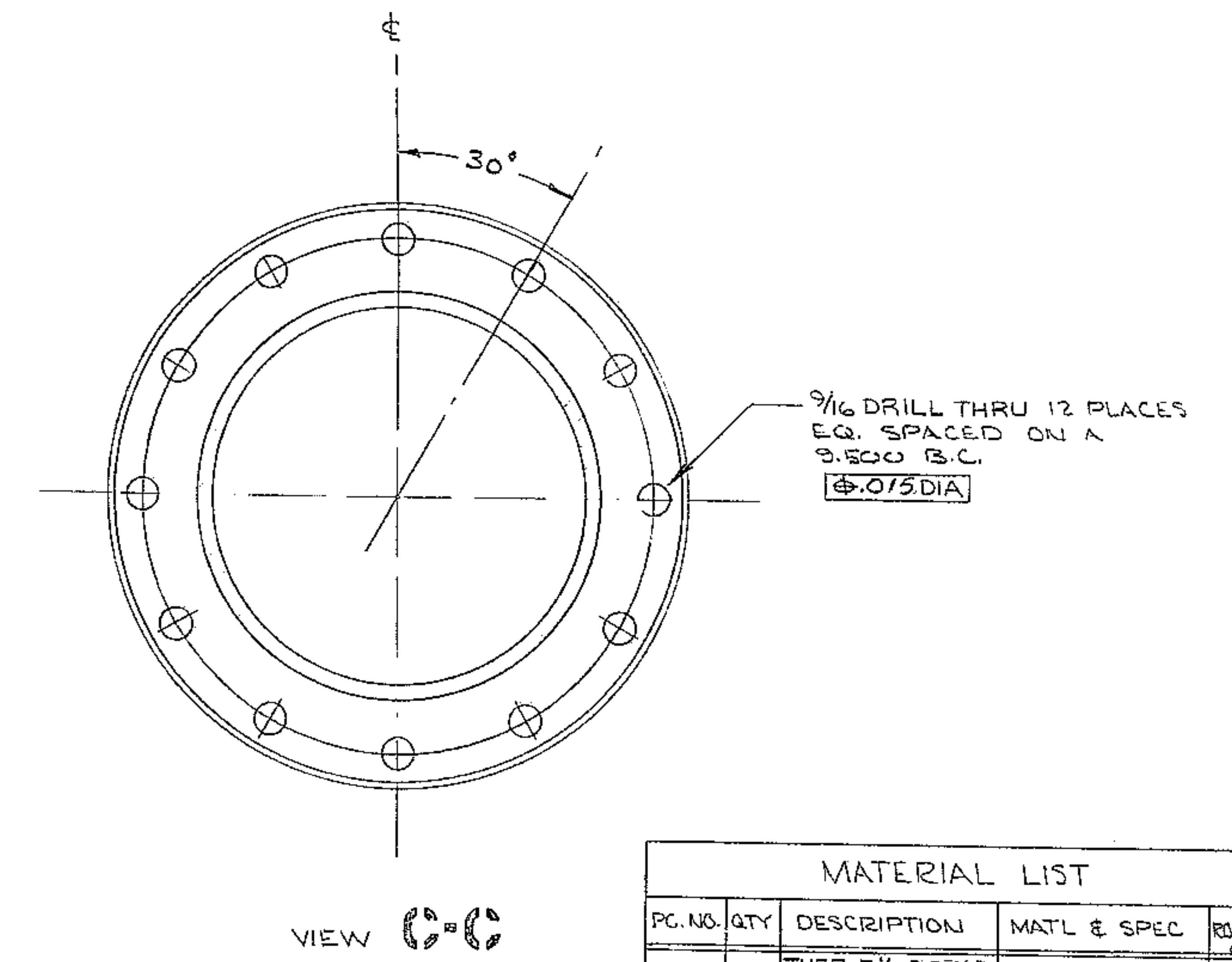

MATERIAL LIST				
PC. NO.	QTY	DESCRIPTION	MAT'L & SPEC.	ROUGH WT
1	1	TUBE 7 1/2 O.D. X 7/8 WALL X 92 1/8 LG	STL A151MT-1015	150
2	1	7 1/2 O.D. X 1.0 X 2 1/2 LONG	STL ASTM A36	18
3	1	TUBE 8 3/4 O.D. X 7/8 WALL X 3 1/2 LG	STL A151MT-1015	19
4	1	R. 10 3/4 O.D. X 7/2 I.D. X 7/8 THK	STL ASTM A36	8
5	1	R. 15 O.D. X 8 3/4 I.D. X 1/2 THK	STL ASTM A36	16.5

TOTAL ROUGH WT = 211.5

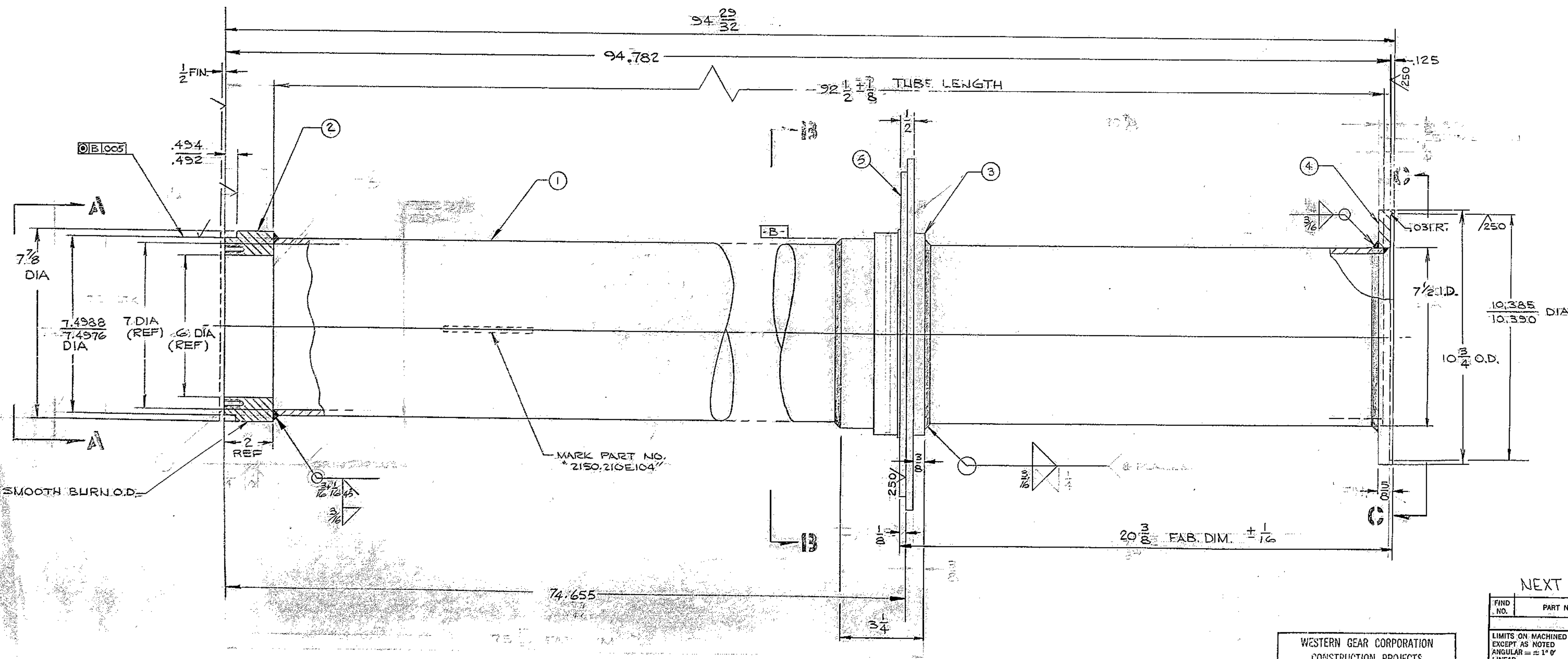

- NOTES:
- ALL DIMENSIONS ARE IN INCHES
 - FABRICATION TOLERANCES EXCEPT AS NOTED.
 - a. UP TO 10 INCHES $\pm \frac{1}{16}$
 - b. 10 TO 50 INCHES $\pm \frac{1}{8}$
 - c. 50 INCHES & OVER $\pm \frac{1}{4}$
 - STRESS RELIEVE AFTER WELDING & BEFORE MACHINING PER W.G.C. SPECIFICATION 510
 - WELD PER W.G.C. SPECIFICATION 752 APP. T1
 - APPLY ONE COAT OF PRIME PAINT ALL OVER PER W.G.C. SPECIFICATION 511 IMMEDIATELY AFTER STRESS RELIEVING. CLEANING
 - ALL SURFACES MARKED \checkmark TO BE \checkmark EXCEPT AS INDICATED.

WESTERN GEAR CORPORATION
 CONSTRUCTION PROJECTS
 DEPARTMENT
 APPROVED FOR
 PROCUREMENT
 DATE 8-1-63

NEXT ASSY 2150.210E102 (WGN102959)

FIND NO.	PART NO.	DESCRIPTION	QTY	MATERIAL	CODE IDENT
LIST OF MATERIAL (L.M.)					
LIMITS ON MACHINED DIMENSIONS EXCEPT AS NOTED					
ANGULAR $\pm 1'0''$					
LINEAR:					
X $\pm .1$ XXX $\pm .010$					
XX $\pm .03$ FRACTIONAL $\pm 1/32$					
CHECK ALL SHARP EDGES					
ENGR					
MATERIAL					
SEE MATL. LIST					
APPROVED					

150 STELLER TELESCOPE MOUNTING
 DRAWN FLAVIN 2-26-63
 CHECKED [Signature] 3-26-63
 ENGR

WESTERN GEAR CORPORATION
 HEAVY MACHINERY DIVISION
 EVERETT, WASHINGTON

INNER TUBE
 P.A. CABLE WRAP-UP

WGN102961
 SIZE CODE IDENT NO. E 16603
 2150.210E104
 REV D

SCALE 1/2 WT 192 LB SHEET 1 OF 1