

REVISIONS				
ZONE	LTR	DESCRIPTION	DATE	APPROVED
B		REVISED & REDRAWN	4-14-69	
C		REVISED PER AURA APPD PRINT	16 OCT 68	
D		NOTE #1 WAS MOBIL PLEX #47 APPROX TO POLY-OIL #3030-410	1-1-69	G.T.



- NOTES:
1. PACK BEARINGS ITEMS # 14, 15 & 16 WITH POLY-OIL # 3030-410. GREASE @ ASS'Y.
 2. APPLY SECOND COAT OF PRIMER & 2 COATS OF FINISH PAINT TO ALL EXPOSED SURFACES EXCEPT AS INDICATED PER WGC SPEC. # 511
 3. HOLES MUST BE CONCENTRIC WITHIN ±.002.
 4. MIC BEARING (P/N 15) & MACHINE LIP ON P/N 4 TO PROVIDE .002 MAX. CLEARANCE.
 5. MIC BEARING (P/N 16) & MACHINE SPACER (P/N 9) FLUSH WITH P/N 2 TO WITHIN .002.

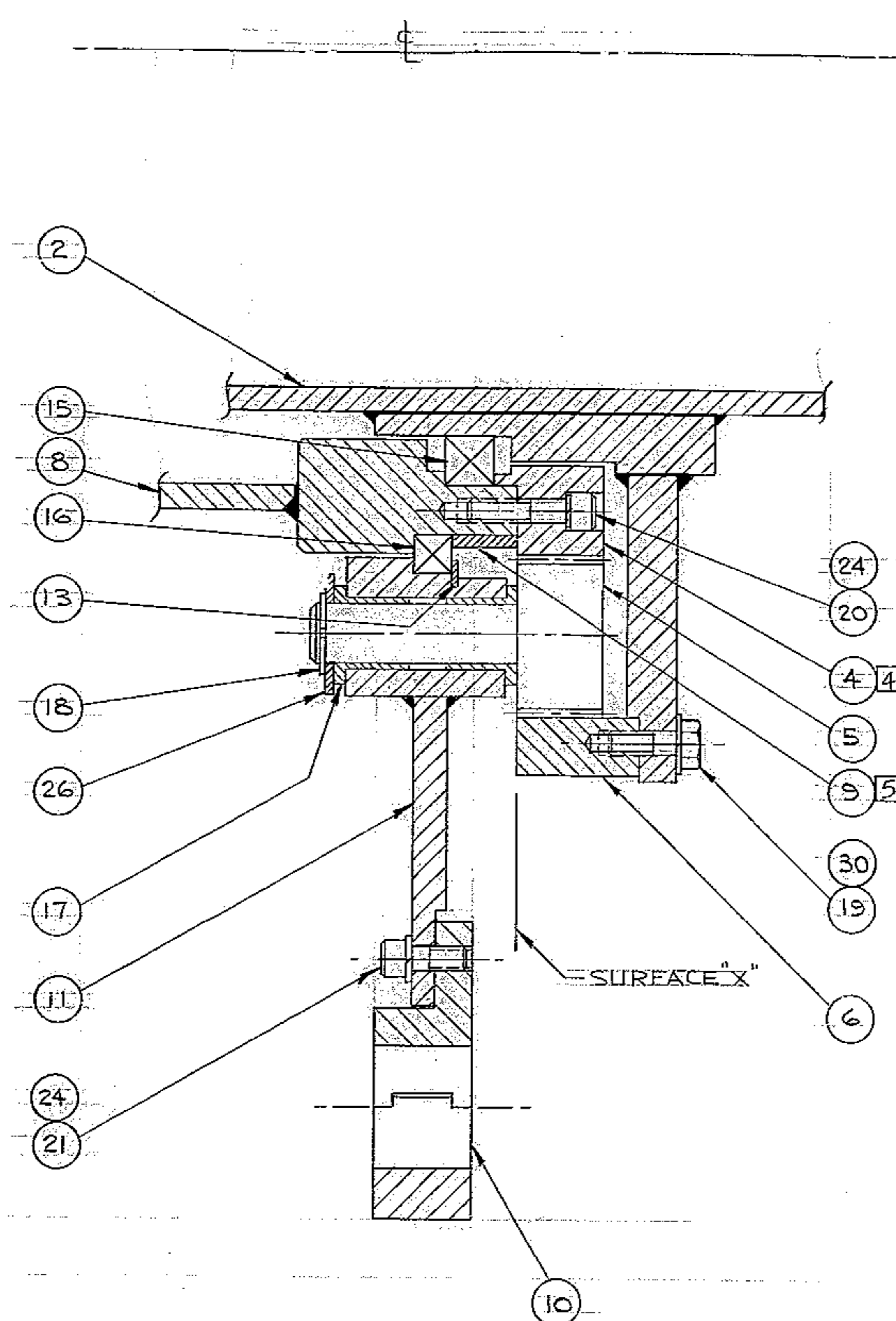
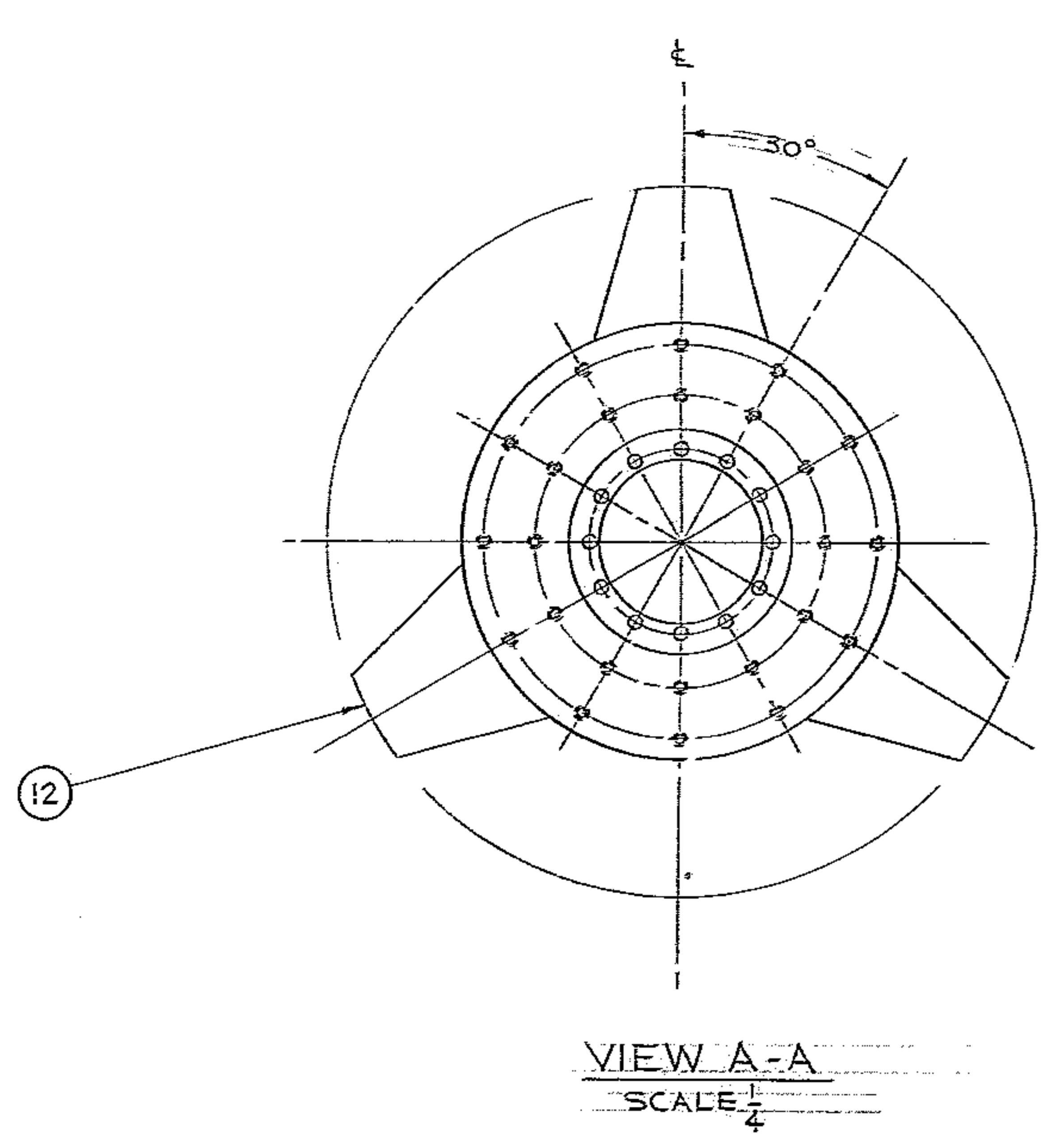
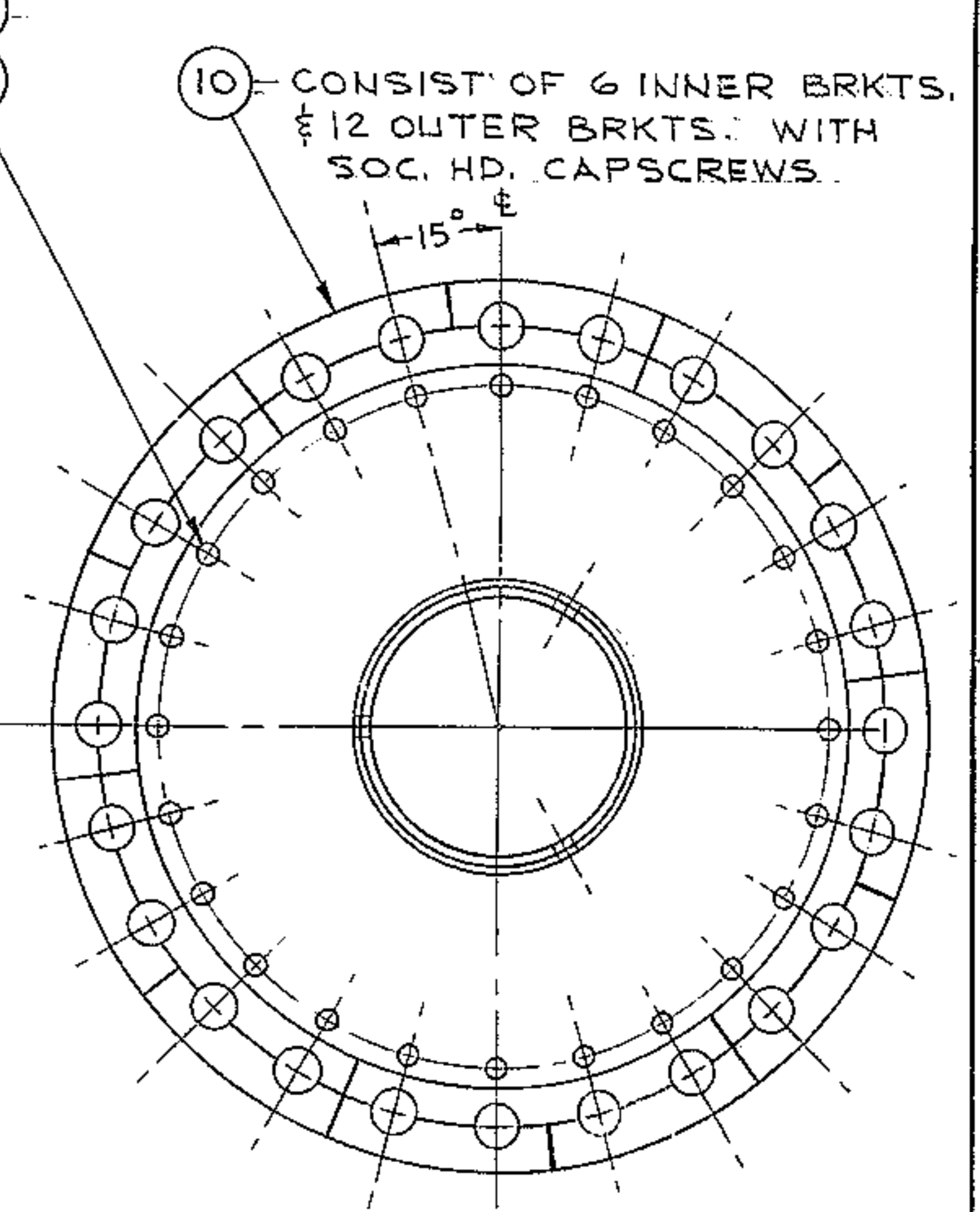

WESTERN GEAR CORPORATION
CONSTRUCTION PROJECTS
DEPARTMENT
APPROVED FOR
PROCUREMENT
G.R. DATE 12/23/69

NEXT ASS'Y. 2150.210E002 (WGN-102 833)

FIND NO.	PART NO.	DESCRIPTION	QTY	MATERIAL	CODE IDENT
LIST OF MATERIAL (LM)					
LIMITS ON MACHINED DIMENSIONS EXCEPT AS NOTED					
ANGULAR = ± 1° 0'					
LINEAR:					
XX ± .1	XXX ± .010				
XX ± .03	FRACTIONAL = ± 1/32				
BREAK ALL SHARP EDGES					
MATERIAL		150°N STELLAR TELESCOPE MTG.			
SEE BILL MAT'L. W.G. C 112, 920		DRAWN McGHEE 4-10-69		WESTERN GEAR CORPORATION HEAVY MACHINERY DIVISION EVERETT, WASHINGTON	
APPROVED		ENGR. <i>W. J. ...</i> 4/14/7		TUBE ASS'Y. P.A. CABLE WRAP UP	
WGN-102.959		SIZE CODE IDENT NO.		REV	
E 16603		2150.210E102		D	
SCALE 1/4		WT 33.6 LB		SHEET 1 OF 1	

REF. FILE 1165