

REVISIONS				
ZONE	LTR	DESCRIPTION	DATE	APPROVED
	A	APPROVED PER AURA APPROVED PRINT	2-14-68	
48	B	34.748 ±.002 WAS 34.748 ±.002	5-30-68	
		34.002 ±.002 WAS 34.002 ±.002		

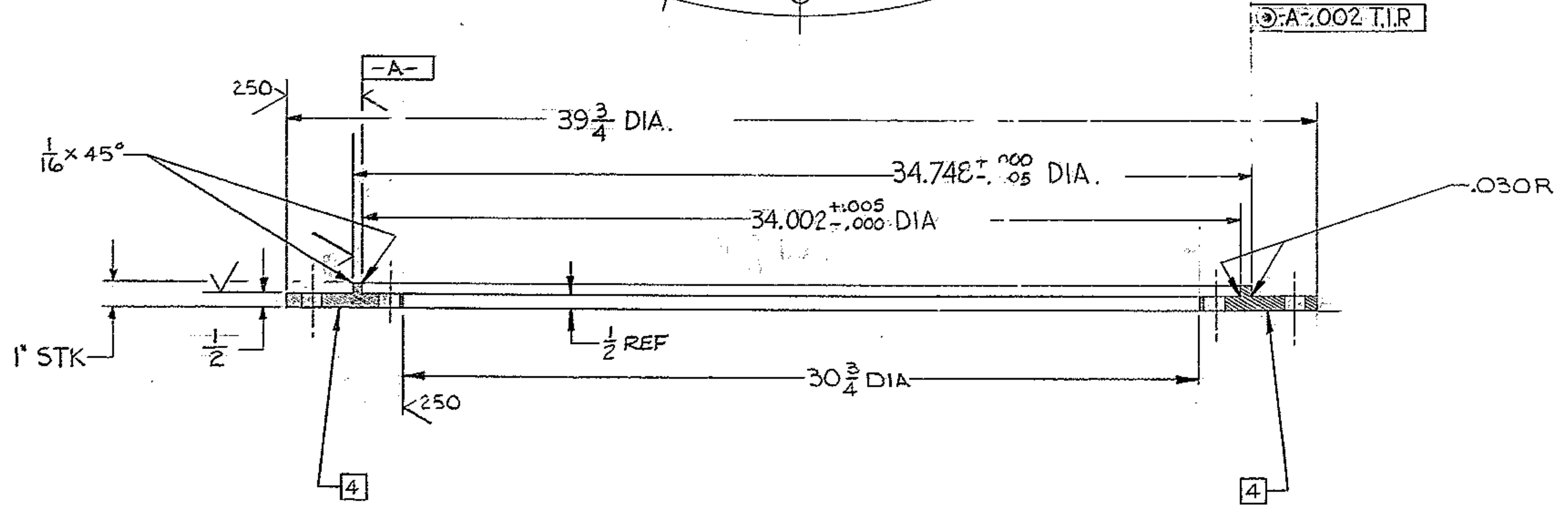
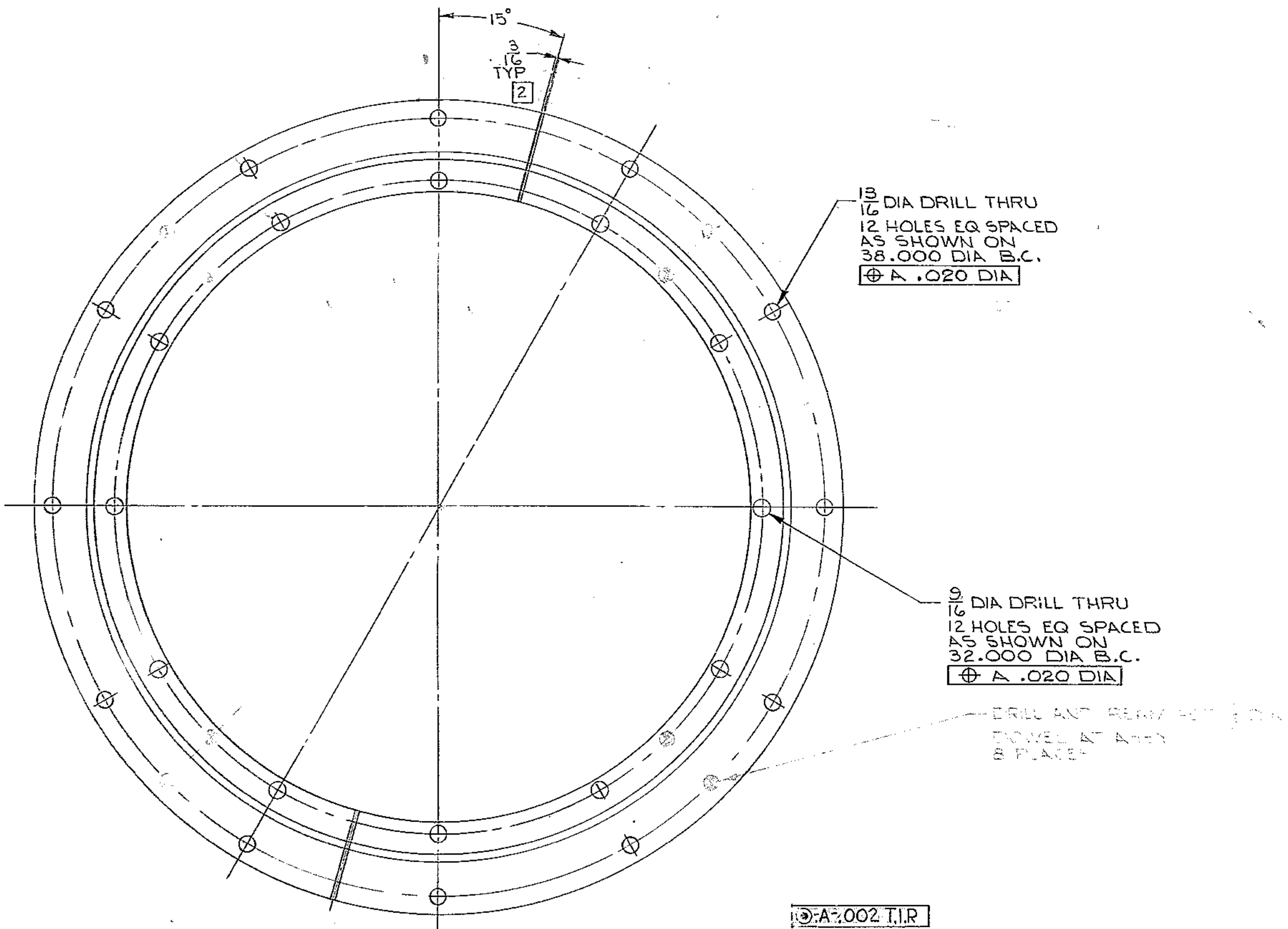

- NOTES:
1. ALL DIMENSIONS ARE IN INCHES.
 2. SAWCUT AFTER DRILLING & TURNING APPROX 3/16 WIDE. KEEP IN PAIRS.
 3. ALL SURFACES MARKED ✓ TO BE 125/ EXCEPT AS NOTED.
 4. STAMP PART NO. 2150.210D012. BOTH HALVES.

WESTERN GEAR CORPORATION
 CONSTRUCTION PROJECTS
 DEPARTMENT
 APPROVED FOR
 PROCUREMENT
 DATE _____

NEXT ASSY: 2150.210E 002 (WGN 102833)

FIND NO.	PART NO.	DESCRIPTION	QTY	MATERIAL	CODE IDENT
LIST OF MATERIAL (LM)					
LIMITS ON MACHINED DIMENSIONS EXCEPT AS NOTED		150 INCH STELLAR TELESCOPE MOUNTING		HEAVY MACHINERY DIVISION EVERETT, WASHINGTON	
ANGULAR = ± 1° 0'		DRAWN L JOHNSON. 3-3-68			
LINEAR:		CHECK Gene Russo 11 APR 68		RING, COUPLING, WRAP-UP POLAR AXLE ASSEMBLY	
X = ± .1 XXX = ± .010		ENGR			
.XX = ± .03 FRACTIONAL = ± 1/32					
BREAK ALL SHARP EDGES					
MATERIAL		WG107574		SIZE CODE IDENT NO. REV	
STL ASTM A7 OR EQUIV.		APPROVED _____		D 16603 2150.210D012 B	
R: 40 1/4 DIA x 30 1/4 I.D x 1 THK		SCALE 1/4"		WT 76 LB SHEET 1 OF 1	

FILE 1165