

4

3

2

1

THIS DOCUMENT CONTAINS INFORMATION PROPRIETARY TO WESTERN GEAR CORPORATION. ALL DESIGN, MANUFACTURING, REPRODUCTION, USE, PATENT AND SALES RIGHTS REGARDING THE SAME ARE HEREBY EXPRESSLY RESERVED BY WESTERN GEAR CORPORATION. THIS DOCUMENT IS SUBMITTED FOR REFERENCE PURPOSES ONLY AND SHALL NOT BE DISCLOSED TO ANY UNAUTHORIZED PERSON OR INCORPORATED INTO ANY OTHER PROJECT.

REVISIONS				
ZONE	LTR	DESCRIPTION	DATE	APPROVED
	A	REL. PER AURA APPD PRINT	15 OCT 69	

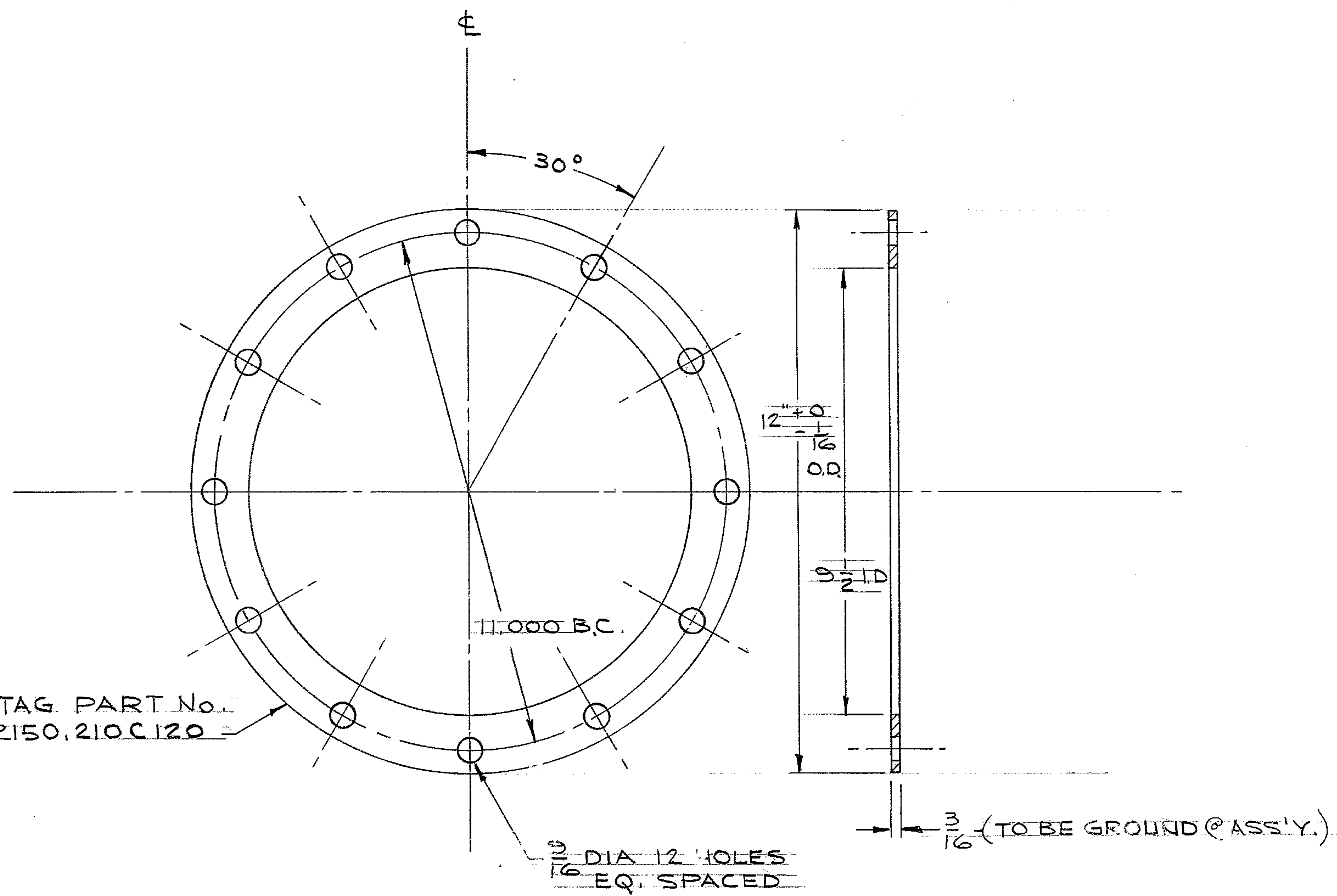

TAG PART No. 2150,210C120

1/16 DIA 12 HOLES EQ. SPACED

3/16 (TO BE GROUND @ ASS'Y.)

NEXT ASS'Y. 2150,210E102 (WGN-102,959)

REV. SHEET 1165

WESTERN GEAR CORPORATION  
CONSTRUCTION PROJECTS  
DEPARTMENT  
APPROVED FOR  
PROCUREMENT  
GR DATE 10/23/69

FIND NO.	PART NO.	DESCRIPTION	QTY	MATERIAL	CODE IDENT
LIST OF MATERIAL (LM)					
LIMITS ON MACHINED DIMENSIONS EXCEPT AS NOTED ANGULAR = ± 1° 0'		150 <sup>IN</sup> STELLAR TELESCOPE MTG.		WESTERN GEAR CORPORATION HEAVY MACHINERY DIVISION EVERETT, WASHINGTON	
LINEAR: .X = ± .1 .XX = ± .03		DRAWN MCGHEE 4-10-69 CHECK ENGR <i>Wingman 11/16/69</i>		SHIM - P.A. CABLE WRAP UP	
BREAK ALL SHARP EDGES		MATERIAL ST'L ASTM A-36 OR EQ.		WGD-107,560	
		APPROVED		SIZE C	CODE IDENT NO. 16603
				2150,210C120	REV A
		SCALE 1/2		WT	LB SHEET 1 OF 1