

THIS DOCUMENT CONTAINS INFORMATION PROPRIETARY TO WESTERN GEAR CORPORATION. ALL DESIGN, MANUFACTURING, REPRODUCTION, USE, PATENT AND SALES RIGHTS REGARDING THE SAME ARE HEREBY EXPRESSLY RESERVED BY WESTERN GEAR CORPORATION. THIS DOCUMENT IS SUBMITTED FOR REFERENCE PURPOSES ONLY AND SHALL NOT BE DISCLOSED TO ANY UNAUTHORIZED PERSON OR INCORPORATED INTO ANY OTHER PROJECT.

REVISIONS				
ZONE	LTR	DESCRIPTION	DATE	APPROVED
	B	REVISED & REDRAWN	4-10-69	<i>[Signature]</i>
	C	REVISED PER AURA APPD PRINT	23 OCT 69	

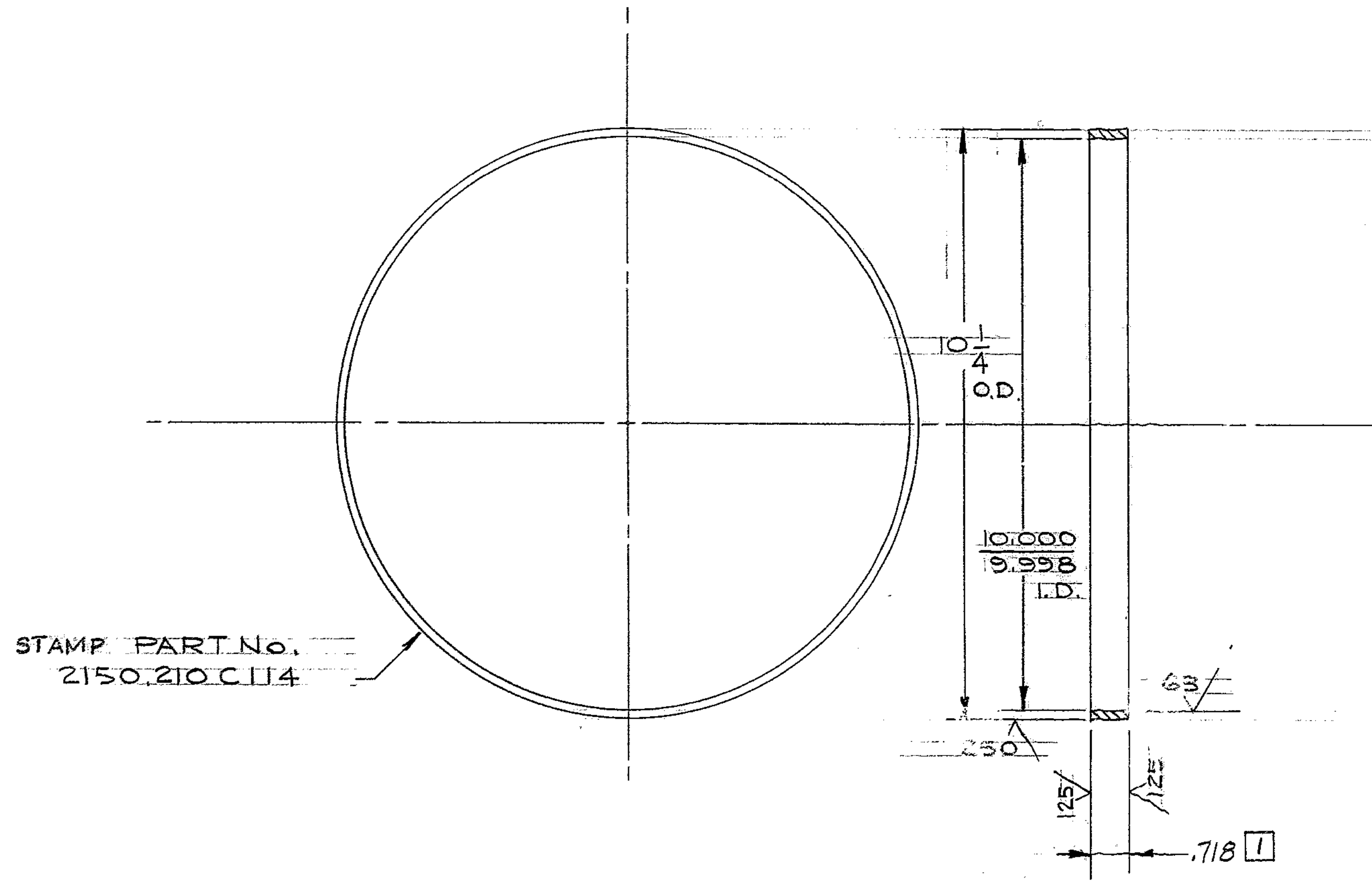

NOTE:
 [1] FINISH DIM. TO BE DETERMINED @ ASSY.
 (SEE DWG 2150.210E102 - W.G.N 102,959)

STAMP PART No. _____
 2150.210C114

NEXT ASS'Y, 2150.210E102 (WGN:102,959)

REF. FILE 1165

WESTERN GEAR CORPORATION
 CONSTRUCTION PROJECTS
 DEPARTMENT
 APPROVED FOR
 PROCUREMENT
 GR DATE 10/23/69

FIND NO.	PART NO.	DESCRIPTION	QTY	MATERIAL	CODE IDENT
LIST OF MATERIAL (LM)					
LIMITS ON MACHINED DIMENSIONS EXCEPT AS NOTED ANGULAR = ± 1° 0'		150" STELLAR TELESCOPE MTG.		Western HEAVY MACHINERY DIVISION GEAR CORPORATION EVERETT, WASHINGTON	
LINEAR: X = ± .1 .XXX = ± .010 XX = ± .03 FRACTIONAL = ± 1/32		DRAWN MCGHEE 4-10-69		SPACER RING PA CABLE WRAP UP	
BREAK ALL SHARP EDGES		CHECK ENGR <i>[Signature]</i> 11/14/69			
MATERIAL SEAMLESS BLACK ST. PIPE 1" LG. 10" SCH. 60 10.75 O.D. x 9.75 I.D. ASTM A-53 GR. B		WGD:107,398		SIZE C	CODE IDENT NO. 2150,210C114
APPROVED				REV C	
SCALE 1/2" = 1" WT _____ # _____ LB SHEET _____ OF _____					