

REVISIONS				
ZONE	LTR	DESCRIPTION	DATE	APPROVED
	A	REVISED PER AURA APP'D PRINT	8-14-69	
	B	REVISED PER AURA PRINT 3-10-69	4-14-69	
	C	REVISED PER AURA APP'D PRINT	23 Oct 69	

MARK WITH PART NO.
"2150.210C106"

9/32 DRILL THRU
C BORE 13/32 DIA x 3/8 DP.
8 HOLES EQ. SPACED
ON A 9.500 B.C. FROM
FAR SIDE
⊕A.010 TIR

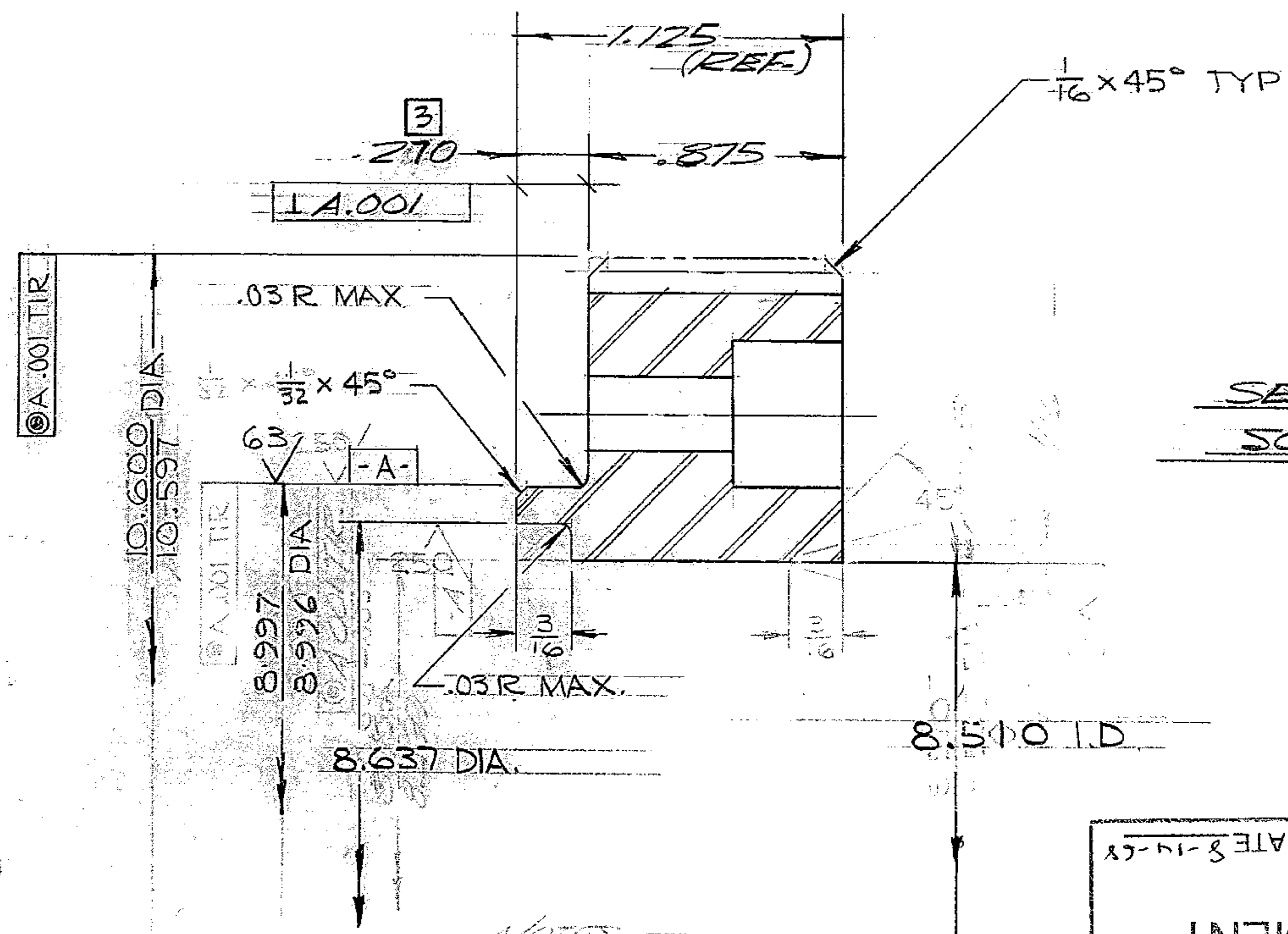
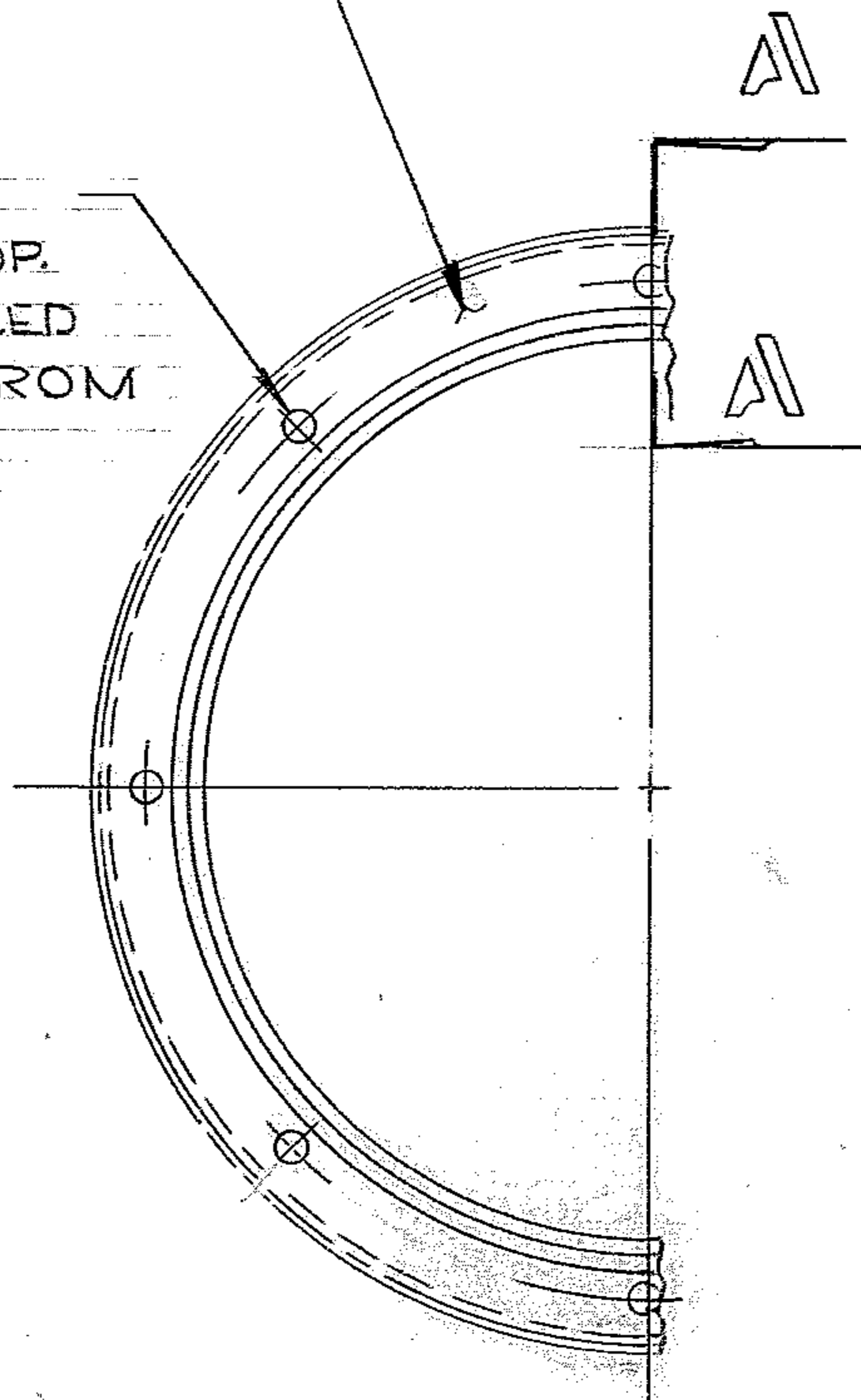

SECTION A-A
SCALE 2/1

- NOTES:
1. ALL DIMENSIONS ARE IN INCHES
 2. FINISH ¹²⁵ ALL OVER UNLESS OTHERWISE NOTED
 3. FINISH DIM. TO BE DETERMINED @ ASSY.
(SEE DWG 2150.210E102 - W.G.N102959)

DATE 8-14-69 GR 14/369
APPROVED FOR
CONSTRUCTION PROJECTS
WESTERN GEAR CORPORATION

- NOTES:
1. ALL DIMENSIONS IN INCHES
 2. FINISH REF TO GEAR MOUNTING SURFACE
 3. MATERIAL

AGMA CLASS B SPUR GEAR DATA	
NUMBER OF TEETH	168
RATIO	7.000/1
PITCH (DIAMETRAL) AGMA ST28	16
PITCH DIAMETER	10.500 (SEE DECR)
PRESSURE ANGLE	20°
ADDENDUM	.0500
DEDENDUM	.0625
CENTER DISTANCE	6.000
NO. TEETH ON MATE	24
METHOD OF CUTTING	HOB
TOTAL BLASH ALL ON STD. CTRS.	.004 - .006
MATES WITH DWG NO'S	2150.210C107 2150.210C108
MEAS. OVER .1080 DIA PINS (.002 - .003 BACKLASH INCL)	10.6481 10.6454

NEXT ASSY: 2150.210E102 (W.G.N102959)

FIND NO.	PART NO.	DESCRIPTION	QTY	MATERIAL	CODE IDENT
LIST OF MATERIAL (LM)					
LIMITS ON MACHINED DIMENSIONS EXCEPT AS NOTED ANGULAR = ± 1° 0'		150 IN. STELLAR TELESCOPE ASSY		Western GEAR CORPORATION HEAVY MACHINERY DIVISION EVERETT, WASHINGTON GEAR-SUN P.A. CABLE WRAP-UP	
LINEAR: X = ± .1 .XXX = ± .010 XX = ± .03 FRACTIONAL = ± 1/32		DRAWN <i>R. NEVET</i> 3-6-68 CHECK <i>J. Nicolay</i> 3-26-68 ENGR			
BREAK ALL SHARP EDGES					
MATERIAL					
STL, SAE 4340		W.G. D107383		SIZE	CODE IDENT NO.
P. 10 3/4 O.D. x 8 1/4 I.D. x 1 1/4		APPROVED		C 16603	2150.210C106
H.T. TO 300/320 BHN				SCALE 1/2	WT 8 LB SHEET 1 OF 1

D-107, 383