

THIS DOCUMENT CONTAINS INFORMATION PROPRIETARY TO WESTERN GEAR CORPORATION. ALL DESIGN, MANUFACTURING, REPRODUCTION, USE, PATENT AND SALES RIGHTS REGARDING THE SAME ARE HEREBY EXPRESSLY RESERVED BY WESTERN GEAR CORPORATION. THIS DOCUMENT IS SUBMITTED FOR REFERENCE PURPOSES ONLY AND SHALL NOT BE DISCLOSED TO ANY UNAUTHORIZED PERSON OR INCORPORATED INTO ANY OTHER PROJECT.

REVISIONS				
ZONE	LTR	DESCRIPTION	DATE	APPROVED
	A	COMPLETELY REDESIGNED	1-23-70	
	B	DELETED TWO DOWEL HOLES	3-28-73	LDS

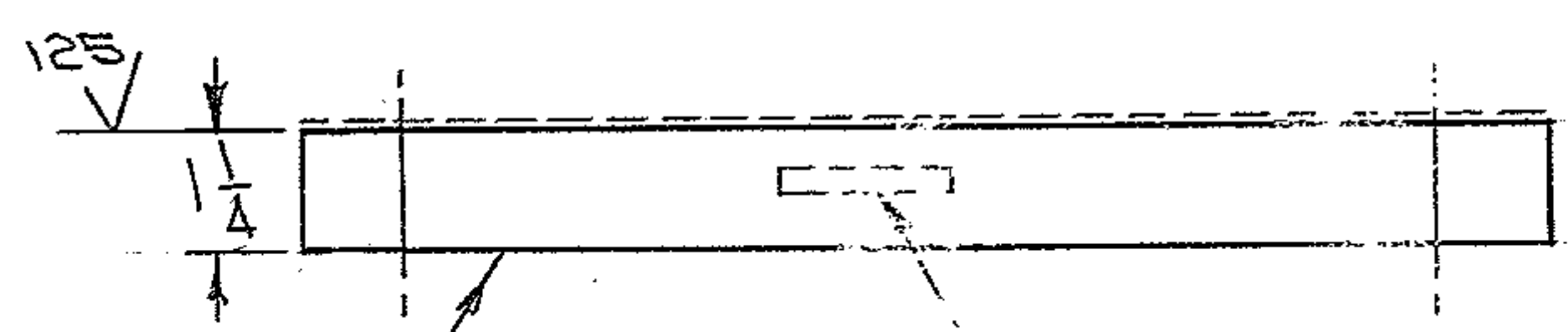
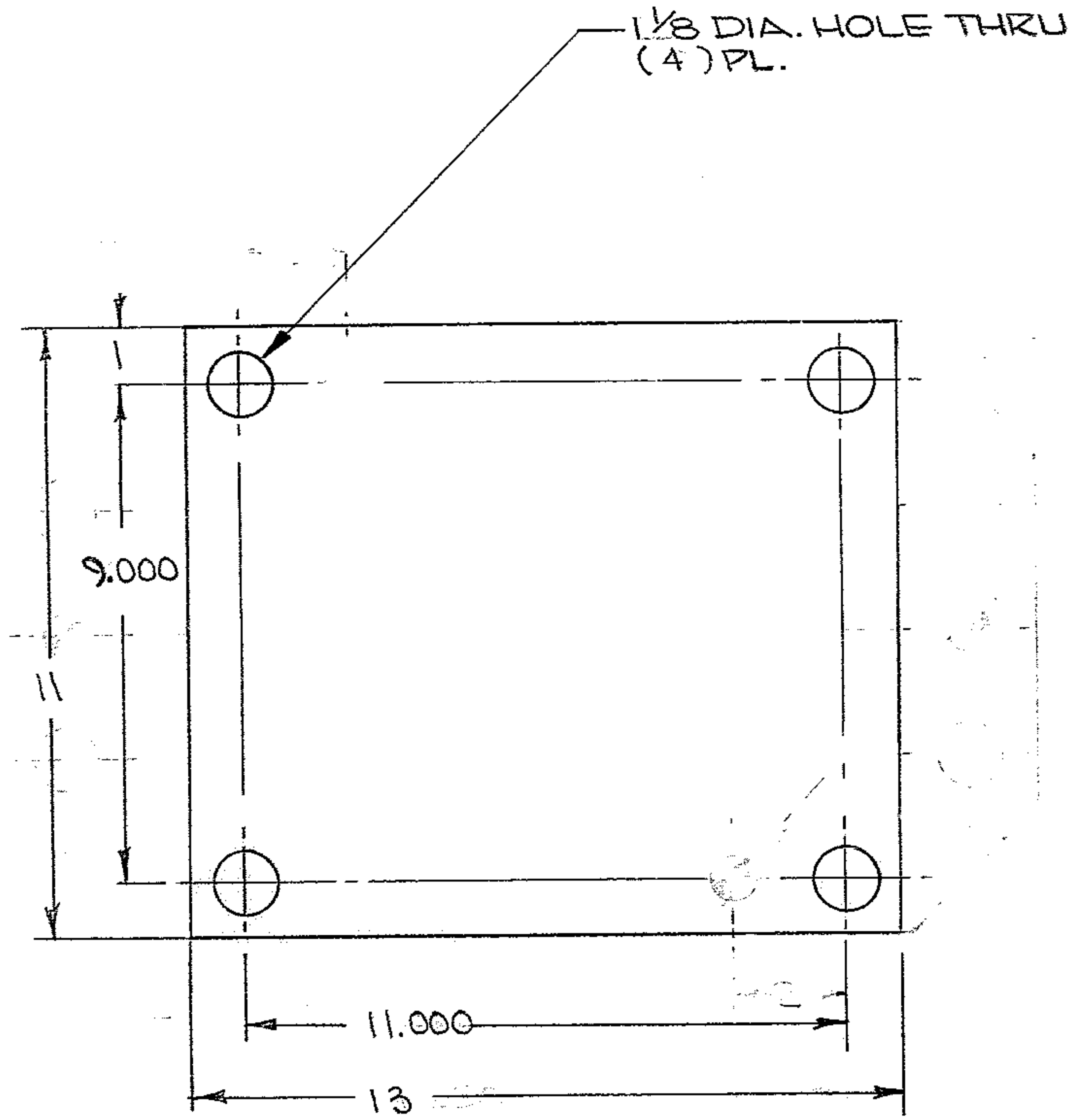

NOTES

- BREAK ALL SHARP EDGES
- HOLE PATTERN TO MATCH PART NO. 2150.281E105 (WGN 102,862) AND 2150.202E012 (WGN 103,551) ON ASSY.

NEXT ASSY: 2150.202 E002

STAMP PART NO. 2150.202C013

CLEARLY MARK THIS SIDE AS "UNFINISHED"

WESTERN GEAR CORPORATION
 CONSTRUCTION PROJECTS
 DEPARTMENT
 APPROVED FOR
 PROCUREMENT
 G. Russo DATE 12/2/69

FIND NO.	PART NO.	DESCRIPTION	QTY	MATERIAL	CODE IDENT
LIST OF MATERIAL (LM)					
LIMITS ON MACHINED DIMENSIONS EXCEPT AS NOTED ANGULAR = ± 1° 0'				WESTERN HEAVY MACHINERY DIVISION GEAR CORPORATION EVERETT, WASHINGTON	
LINEAR: X = ± .1 .XXX = ± .010 .XX = ± .03 FRACTIONAL = ± 1/32		DRAWN <i>E. J. H.</i> 7/24/69		SHIM-SERRURIER TRUSS ALIGNMENT	
BREAK ALL SHARP EDGES		CHECK			
MATERIAL		ENGR <i>Wingman</i> 7/28/69		SIZE C CODE IDENT NO. 16603 2150.202C013 REV B	
11 x 1 3/8 x 13 ASTM A36 STL		WGD 107,563 APPROVED			
		SCALE 1/3		WT 55.3 LB SHEET 1 OF 1	

D-107-563

1164