

THIS DOCUMENT CONTAINS INFORMATION PROPRIETARY TO WESTERN GEAR CORPORATION. ALL DESIGN, MANUFACTURING, REPRODUCTION, USE, PATENT, AND SALES RIGHTS REGARDING THE SAME ARE HEREBY EXPRESSLY RESERVED BY WESTERN GEAR CORPORATION. THIS DOCUMENT IS SUBMITTED FOR REFERENCE PURPOSES ONLY AND SHALL NOT BE DISCLOSED TO ANY UNAUTHORIZED PERSON OR INCORPORATED INTO ANY OTHER PROJECT.

REVISIONS				
ZONE	LTR	DESCRIPTION	DATE	APPROVED
	A	ADDED NOTES 4 & 5	1/24/72	G.R.

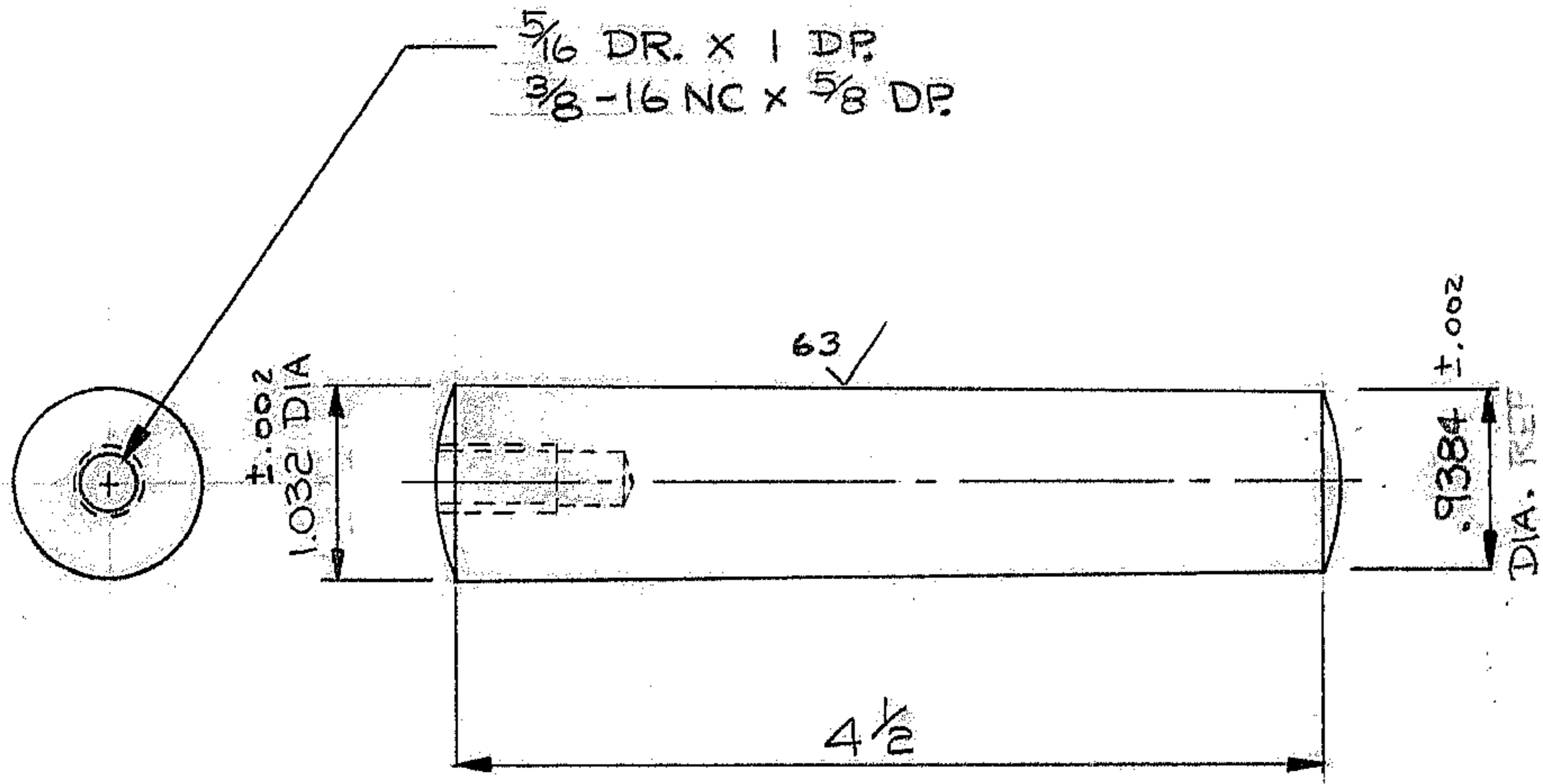

- NOTES:
- MAT'L: MAKE FROM STD. STEEL #12 TAPER DOWEL PIN, 4 1/2" LONG.
 - ALL DIMENSIONS IN INCHES.
 - TAG " PART NO. 2150.202 B014 "
 - OPTION MFG. COMPLETE USING AISI C1095 HT TO 350 BHN MIN OIL QUENCH FROM 1475°F TEMPER AT 900°F
 - SMALL CENTERS ARE PERMISSABLE

REF. FILE 1164

NEXT ASSY. 2150.202 B002 (W.G. N-103,026)

WESTERN GEAR CORPORATION
 CONSTRUCTION PROJECTS
 DEPARTMENT
**APPROVED FOR
 PROCUREMENT**
Chen DATE 12/1/69

LIMITS ON MACHINED DIMENSIONS EXCEPT AS NOTED ANGULAR ± 1° 0' LINEAR X = ± .1 XX = ± .03 XXX = ± .010 FRACTIONAL ± 1/32	150" STELLAR TELESCOPE		WESTERN HEAVY MACHINERY DIVISION GEAR CORPORATION EVERETT, WASHINGTON	
	DRAWN COOPER 20/11/69		DOWEL, TAPER, NO. 12	
CHECK [Signature] 20 NOV 69		SIZE B CODE IDENT NO. 16603 2150.202 B014		
ENGR		REV A		
W.G. B-300,640		SCALE FULL WT. — LB SHEET OF		
APPROVED				

BREAK ALL SHARP EDGES