

5

4

3

2

1

"THIS TECHNICAL DATA, FURNISHED UNDER UNITED STATES GOVERNMENT CONTRACT NO. _____, SHALL NOT BE EITHER RELEASED OUTSIDE THE GOVERNMENT, OR USED, DUPLICATED, OR DISCLOSED IN WHOLE OR IN PART FOR MANUFACTURE OR PROCUREMENT, WITHOUT THE WRITTEN PERMISSION OF WESTERN GEAR CORPORATION EXCEPT FOR (I) EMERGENCY REPAIR OR OVERHAUL WORK BY OR FOR THE GOVERNMENT WHERE THE ITEM OR PROCESS CONCERNED IS NOT OTHERWISE REASONABLY AVAILABLE TO ENABLE TIMELY PERFORMANCE OF THE WORK OR (II) RELEASE TO A FOREIGN GOVERNMENT AS THE INTERESTS OF THE UNITED STATES MAY REQUIRE; PROVIDED THAT IN EITHER CASE THE RELEASE, USE, DUPLICATION OR DISCLOSURE HEREOF SHALL BE SUBJECT TO THE FOREGOING LIMITATIONS. THIS LEGEND SHALL BE MARKED ON ANY REPRODUCTION HEREOF IN WHOLE OR IN PART."

REVISIONS				
ZONE	LTR	DESCRIPTION	DATE	APPROVED

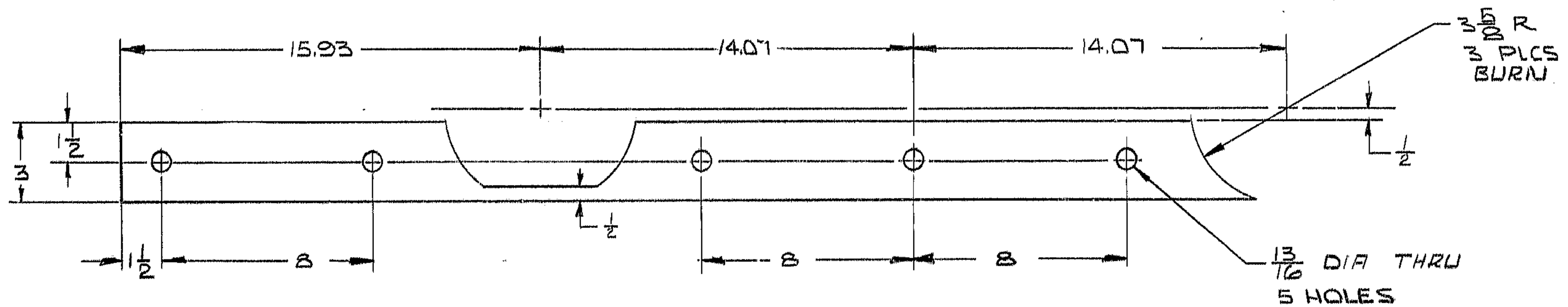

REF. FILE 1163

NEXT ASSY 2150.201E002

MAT'L: STL-ASTM A-36 - 1/4 THK. X 3 X 4 3/2

LIMITS ON MACHINED DIMENSIONS EXCEPT AS NOTED ANGULAR ± 1° 0' LINEAR X = ± .1 XX = ± .03 XXX = ± .010 FRACTIONAL ± 1/32 BREAK ALL SHARP EDGES	150" STELLAR TELESCOPE	WESTERN HEAVY MACHINERY DIVISION GEAR CORPORATION EVERETT, WASHINGTON
	DRAWN <i>LDS</i>	SPACER KPNO
	CHECK	P.A. CABLE W.L. SUPPORT
	ENGR <i>LDS</i>	POLAR AXIS ASSEMBLY
APPROVED	SIZE B CODE IDENT NO. 16603 2150.2013017	REV
SCALE 1/4	WT. — LB	SHEET 1 OF 1