

4

3

2

1

WESTERN GEAR CORPORATION
 CONSTRUCTION PROJECTS
 DEPARTMENT
 APPROVED FOR
 PROCUREMENT
 DATE 6-22-68

REVISIONS				
ZONE	LTR	DESCRIPTION	DATE	APPROVED
	A	REVISED PER A.U.R.A. APP PRINT.	6/22/68	
4-CD	B	CHANGED DIM. 14 5/8 MIN WAS 14 1/4 & 17 5/8 MAX WAS 17 7/8	2/2/69	

D

C

B

A

D

C

B

A

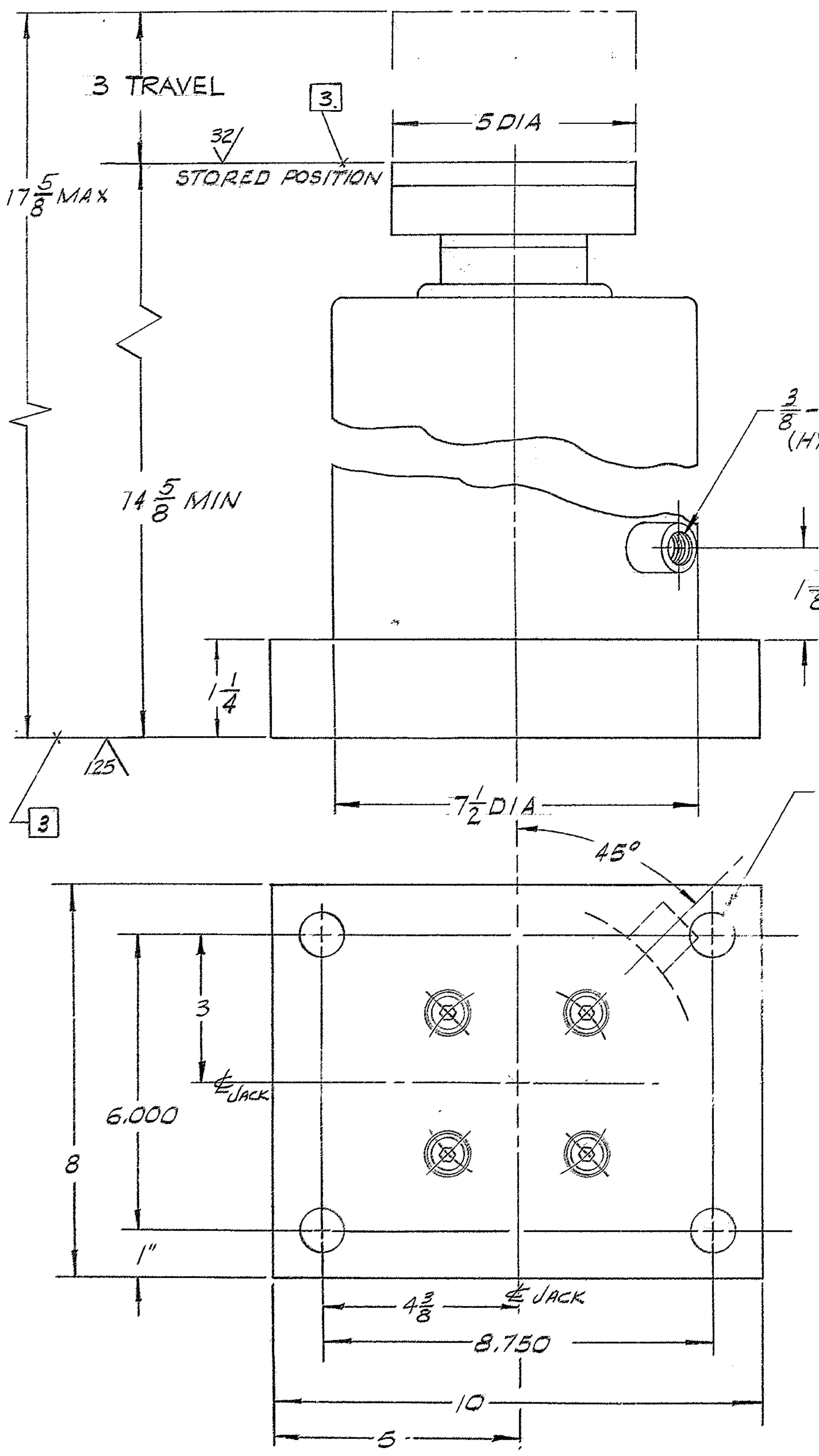

NOTE:

1. ALL DIMENSIONS ARE IN INCHES.
2. FABRICATION TOLERANCES, EXCEPT AS NOTED
 UP TO 10 INCHES ± 1/16
 UP TO 50 INCHES ± 1/8
 50 INCHES AND OVER ± 1/4
3. FINISH PAINTED ALL OVER EXCEPT SURFACES MARKED 3
4. RAM : 100 TON CAPACITY. @ 9450 CAPACITY. WITHOUT SPRING.

NEXT ASSY: 2150.100E 002 (W.G.N 102845)
 2150.101E 101 (W.G.N 102846)

REF. FILE 1162

FIND NO.	PART NO.	DESCRIPTION	QTY	MATERIAL	CODE IDENT
LIST OF MATERIAL (LM)					
LIMITS ON MACHINED DIMENSIONS EXCEPT AS NOTED ANGULAR = ± 1° 0'		150 ^{LN} STELLAR TELESCOPE MOUNTING		Western GEAR CORPORATION HEAVY MACHINERY DIVISION EVERETT, WASHINGTON	
LINEAR: .X = ± .1 .XXX = ± .010 .XX = ± .03 FRACTIONAL = ± 1/32		DRAWN: <u>JB</u> 4.12.68 CHECK: <u>GENE RUSSO</u> 24 APR 68		THRUST JACK OUTLINE	
BREAK ALL SHARP EDGES		ENGR			
MATERIAL		W.G.D 107469		SIZE	CODE IDENT NO.
		APPROVED		C 16603	2150.190C 501
				SCALE 6"=10"	WT 136
				LB	SHEET 1 OF 1
				REV	B

