

WESTERN GEAR CORPORATION
 CONSTRUCTION PROJECTS
 DEPARTMENT
 APPROVED FOR
 PROCUREMENT

DATE 6-22-68

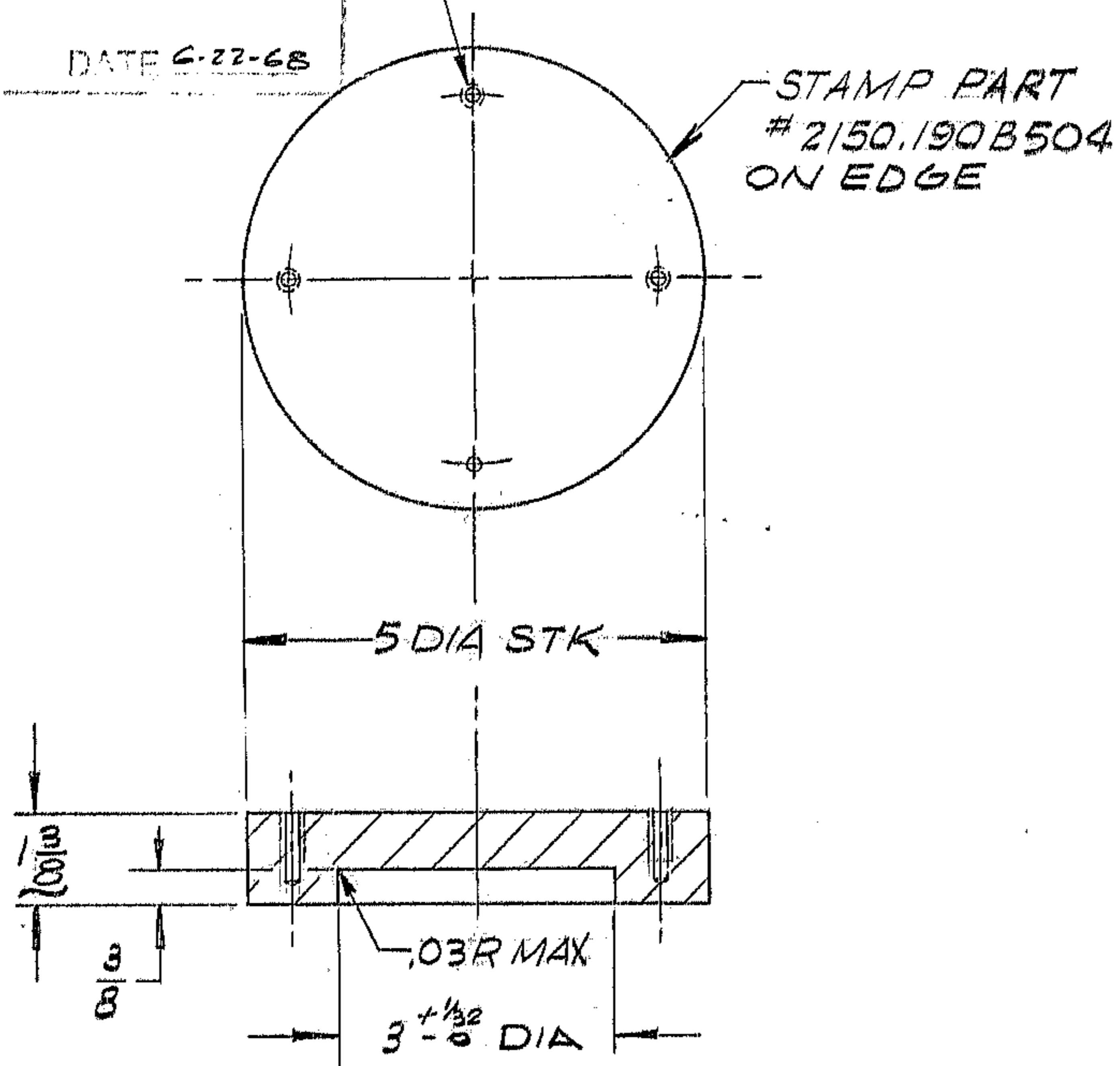

#7 (201) DRILL X 3/4 DEEP MIN
 TAP 1/4 - 20 UNC - 2B X 1/2 DEEP MIN
 4-PLACES EQ SP ON 4.000 D.B.C.

STAMP PART
 #2150.190B504
 ON EDGE

NOTE:

- 1- ALL DIMENSION ARE IN INCHES.
2. MAT'L: STL ASTM A-70 REQ. 5" DIA X 1 5/8 LG
3. FINISH 125/ ALL OVER EXCEPT AS NOTED

REVISIONS				
ZONE	LTR	DESCRIPTION	DATE	APPROVED
	A	REVISED PER AURA APP PRINT.	6/22/68	

NEXT ASS'Y 2150.190C502 (W.G. D 107,467)

REF. FILE 1162

LIMITS ON MACHINED DIMENSIONS EXCEPT AS NOTED ANGULAR ± 1° 0' LINEAR .X = ± .1 .XX = ± .03 .XXX = ± .010 FRACTIONAL ± 1/32 BREAK ALL SHARP EDGES	150" STELLAR TELESCOPE MOUNTING	Western GEAR CORPORATION HEAVY MACHINERY DIVISION EVERETT, WASHINGTON			
	DRAWN J. Brown	SUPPORT DISC THRUST JACK			
	CHECK J. McLaughlin				
	ENGR	WGC 112472	SIZE B	CODE IDENT NO. 16603	2150.190B504
APPROVED		SCALE 1/2	WT. 7	LB SHEET	OF 1