

5

4

3

2

1

REVISIONS				
ZONE	LTR	DESCRIPTION	DATE	APPROVED
	A	REVISED PER A.U.R.A. APP PRINT.	6/22/68	

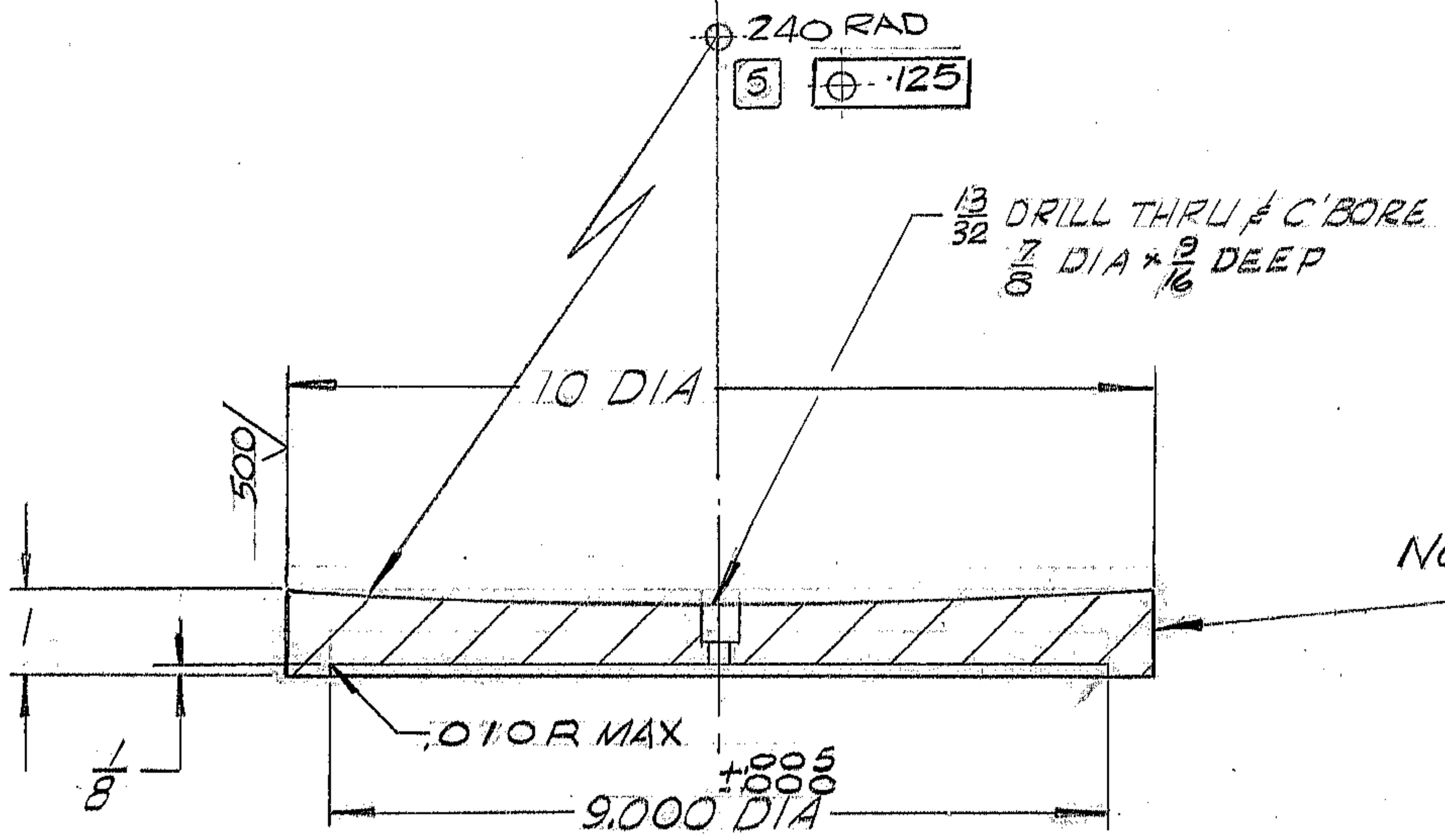

NOTES:

- 1. STAMP PART NO 2150.190 B007.
- 2. MAT'L BRASS, A.S.T.M. B36 ALLOY G OR SAE 70E ANNEALED TO 1/8 HARD MAX, 10 DIA x 1 THICK.
- 3. FINISH 125 ALL OVER EXCEPT AS NOTED
- 4. ALL DIMENSIONS ARE IN INCHES.
- 5. MATCH RADIUS WITH 2150-251E002 FOR 75% MIN CONTACT.

REF. FILE 1162

NEXT ASS'Y 2150.190 D 202 (W.G.D 107476)
 2150.190 C 102 (W.G.D 107477)

WESTERN GEAR CORPORATION
 CONSTRUCTION PROJECTS
 DEPARTMENT
 APPROVED FOR
 PROCUREMENT
 DATE 6-22-68

LIMITS ON MACHINED DIMENSIONS EXCEPT AS NOTED ANGULAR ± 1° 0' LINEAR .X = ± .1 .XX = ± .03 .XXX = ± .010 FRACTIONAL ± 1/32 BREAK ALL SHARP EDGES	150" STELLAR TELESCOPE MOUNTING	Western GEAR CORPORATION HEAVY MACHINERY DIVISION EVERETT, WASHINGTON	
	DRAWN <i>Swain</i> CHECK <i>Michalski</i> ENGR	CAP, RAM, NORTH JACK	
W.G.C 112495	APPROVED	SIZE B	CODE IDENT NO. 16603
		SCALE 1/2	WT. 26 LB SHEET 1 OF 1
			2150.190 B007
			REV A