

REVISIONS				
ZONE	LTR	DESCRIPTION	DATE	APPROVED
	A	REVISED PER A.U.R.A. APP PRINT.	6/21/68	

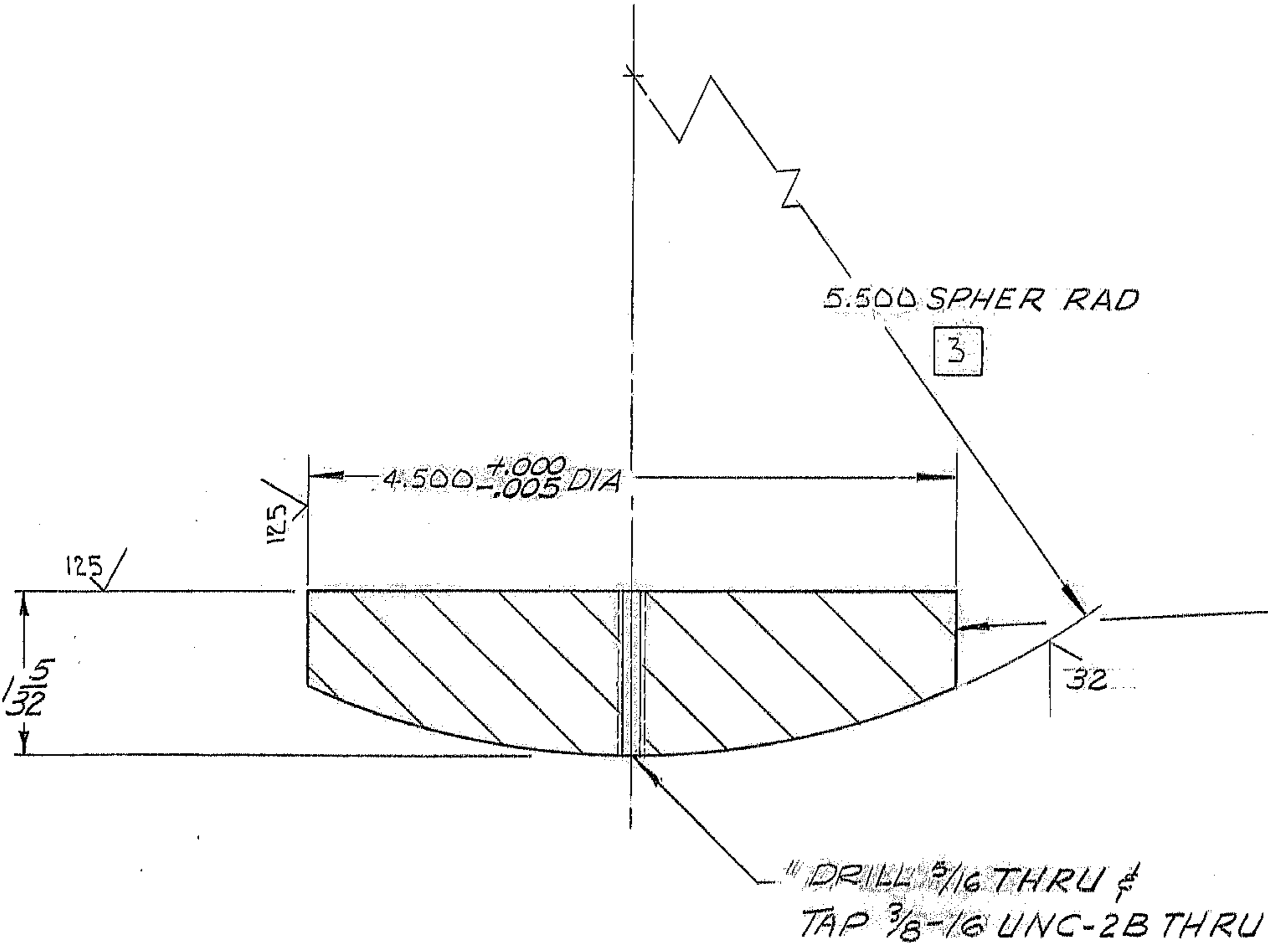

- NOTE:
1. STAMP PART NO. "2150.190B004"
 2. MAT'L : STL AISI C-1018 , 4 3/4 DIA. X 1 3/8 LG
 3. LAP AT ASSY PER INSTRUCTIONS ON NEXT ASSY DWGS.
 4. ALL DIMENSIONS ARE IN INCHES.

WESTERN GEAR CORPORATION
 CONSTRUCTION PROJECTS
 DEPARTMENT
 APPROVED FOR
 PROCUREMENT
 DATE 6-22-68

NEXT ASSY: 2150.190C402 (W.G. D 107419)
 2150.190C302 (W.G. D 107418)

REF. FILE 1162

LIMITS ON MACHINED DIMENSIONS EXCEPT AS NOTED ANGULAR ± 1° 0' LINEAR .X = ± .1 .XX = ± .03 .XXX = ± .010 FRACTIONAL ± 1/32 BREAK ALL SHARP EDGES	150 LB STELLAR TELESCOPE MOUNTING	Western GEAR CORPORATION HEAVY MACHINERY DIVISION EVERETT, WASHINGTON	
	DRAWN <i>Johnny Bloom</i> CHECK <i>Gene Russo / APR 68</i> ENGR	SWIVEL PAD — SOUTH JACK ASSY	
WGC 112418	SIZE B	CODE IDENT NO. 16603	REV A
APPROVED	SCALE 1/1	WT. 4. LB	SHEET 1 OF 1