

REVISIONS				
ZONE	LTR	DESCRIPTION	DATE	APPROVED
A		REVISED PER AURA APPD, CONST. PRINT DATED 17 FEB 68	2/24/68	

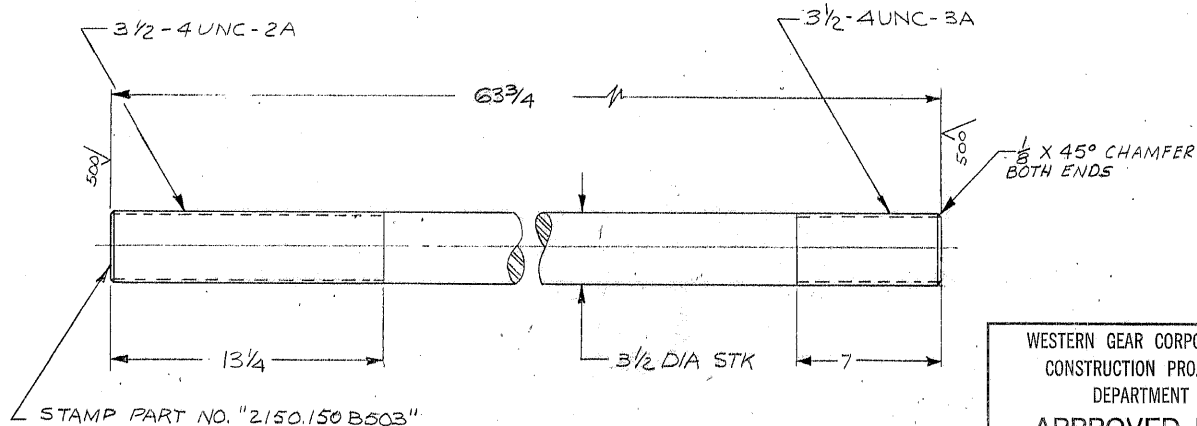

WESTERN GEAR CORPORATION  
CONSTRUCTION PROJECTS  
DEPARTMENT  
APPROVED FOR  
PROCUREMENT

SIGNED *John A. Shaller* DATE FEB 24 1968

REF. FILE 1158

NOTES:

1. MAT'L: A.I.S.I. 1040 STL OR EQUIV (90,000 PSI MIN YIELD)
2. APPLY ONE COAT OF PRIME PAINT ALL OVER BEFORE MACHINING PER W.G.C. SPECIFICATION 511.
3. ALL DIMENSIONS IN INCHES.

NEXT ASSEMBLY: 2150.150 D502 (W.G.E 107,527)

LIMITS ON  
MACHINED DIMENSIONS  
EXCEPT AS NOTED  
ANGULAR  $\pm 1^{\circ} 0'$   
LINEAR  
XX  $\pm .1$   
XX  $\pm .03$   
XXX  $\pm .010$   
FRACTIONAL  $\pm 1/32$   
BREAK ALL  
SHARP EDGES

150 IN STELLAR  
TELESCOPE MOUNTING  
DRAWN *G. TRACER 12/16*  
CHECK *Gene Russo 4 Feb 68*  
ENGR  
W.G.C 112,311  
APPROVED  
ORIG

WESTERN GEAR CORPORATION HEAVY MACHINERY DIVISION  
EVERETT, WASHINGTON  
STUD, KPNO  
SOUTH SEISMIC ANCHOR  
SIZE B CODE IDENT NO. 2150.150 B503 REV A  
SCALE 1/4 WT. 174 LB SHEET 1 OF 1