

THIS TECHNICAL DATA FURNISHED UNDER UNITED STATES GOVERNMENT CONTRACT NO. SHALL NOT BE EITHER RELEASED OUTSIDE THE GOVERNMENT, OR USED, INDICATED, OR DISCLOSED IN WHOLE OR IN PART FOR MANUFACTURE OR PROCESSING, WITHOUT THE WRITTEN PERMISSION OF WESTERN GEAR CORPORATION EXCEPT FOR (1) REPAIRS OR REPLACEMENT WORK BY OR FOR THE GOVERNMENT WHERE THE FIT OR PROCESS CONCERNED IS NOT OTHERWISE REASONABLY AVAILABLE TO INSURE TIMELY PERFORMANCE OF THE WORK OR (2) RELEASE TO A FOREIGN GOVERNMENT AS THE INTERESTS OF THE UNITED STATES MAY BECOME PROMOTED THAT IN EITHER CASE THE RELEASE USE, DISCLOSURE OR DISSEMINATION SHALL BE SUBJECT TO THE FOLLOWING LIMITATIONS, THE WORDS SHALL BE MARKED ON ANY REPRODUCTION HEREOF BY WORK OR IN PART.

REVISIONS					
ZONE	LTR	DESCRIPTION	DATE	APPROVED	
A	REV	NEXT ASSY REQ.	3/17/72	LZS	

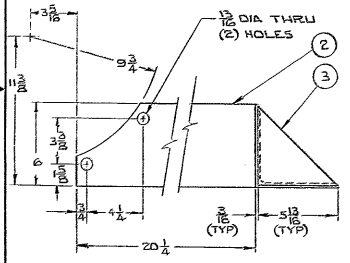
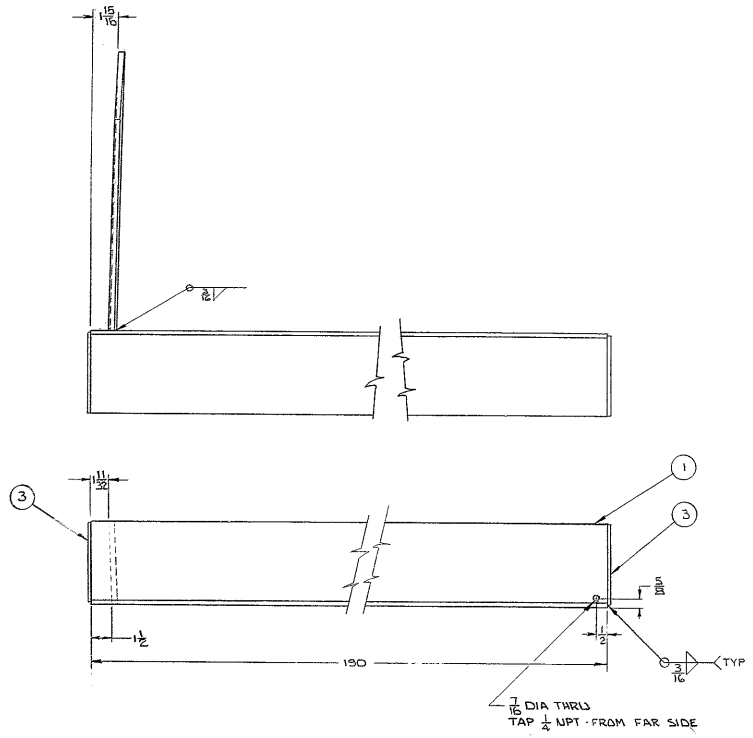

- NOTES.
1. STL STAMP P/N 2150.140D033.
 2. SAND BLAST TO CLEAN UP.
 3. APPLY ONE COAT OF PRIME PAINT.

1157

NEXT ASSY: 2150.141 E007
2150.140 E002 (N102845)

ITEM NO.	PART NO.	DESCRIPTION	QTY	MATERIAL	CODE IDENT
3		1/4 X 5/16 X 5/16	2	STL ASTM A-36	
2		1/8 X 6 X 20 1/4	1	STL ASTM A-36	
1		5/16 X 6 X 6 ANGLE 90°	1	STL ASTM A-36	

LIMITS ON MACHINED DIMENSIONS UNLESS AS NOTED		DRAWN L.D.S.		WESTERN HEAVY MACHINERY DIVISION	
ANGULAR	± 1°	3-21-72	3-21-72	WEAR CORPORATION	EVERETT, WASHINGTON
LINEAR	± .01	CHECK		OIL CATCH	
FRACTIONAL	± 1/32	ENGR SKILES	3-21-72		
MATERIAL					
SEE L/M		WG D30A008		SIZE	CODE IDENT NO.
APPROVED				D 16603	2150.140 D033
				SCALE 3/4"	WT
				LB	SHEET OF