

THIS DOCUMENT CONTAINS INFORMATION PROPRIETARY TO WESTERN GEAR CORPORATION. ALL DESIGN, MANUFACTURING, REPRODUCTION, USE, PATENT, AND SALES RIGHTS REGARDING THE SAME ARE HEREBY EXPRESSLY RESERVED BY WESTERN GEAR CORPORATION. THIS DOCUMENT IS SUBMITTED FOR REFERENCE PURPOSES ONLY AND SHALL NOT BE DISCLOSED TO ANY UNAUTHORIZED PERSON OR INCORPORATED INTO ANY OTHER PROJECT.

## REVISIONS

ZONE	LTR	DESCRIPTION	DATE	APPROVED

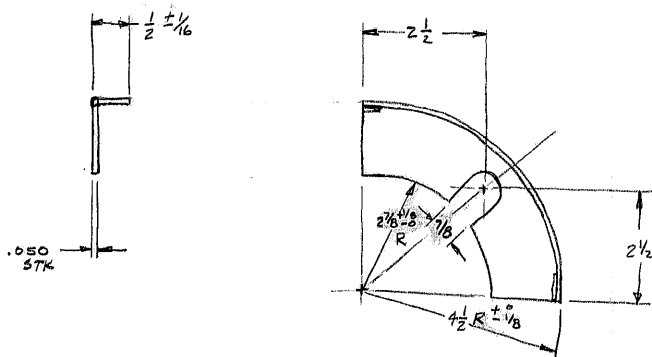

## NOTES:

1. MATL: STEEL SHEET .050
2. DEBURR
3. (2) REQD
4. STL STAMP WITH PIN 2150.120 B013

REF.	
FILE	1155

NEXT ASSY 2150.120 E 202  
2150.120 E 101

W.O. 4826

LIMITS ON MACHINED DIMENSIONS EXCEPT AS NOTED ANGULAR ± 1° 0' LINEAR X = ± .1 XX = ± .03 XXX = ± .010 FRACTIONAL ± <del>XXX</del> ± 1/16	150 IN TELESCOPE	<b>WESTERN</b> GEAR CORPORATION	HEAVY MACHINERY DIVISION EVERETT, WASHINGTON			
	DRAWN G. Russo 7/20/72		CHECK	OIL GUIDE S. RADIAL BRGS.		
BREAK ALL SHARP EDGES	WG B3047B	APPROVED	SIZE B	CODE IDENT NO. 16603	2150.120B013	REV -
	SCALE 1/2	WT. -	LB	SHEET 1	OF 1	