

5

4

3

2

1

REVISIONS

ZONE	LTR	DESCRIPTION	DATE	APPROVED
-	A	REL TO MFG	1/29/69	JBT
B		WG DWG NO. WAS C107432	1/19/69	W. S. W.

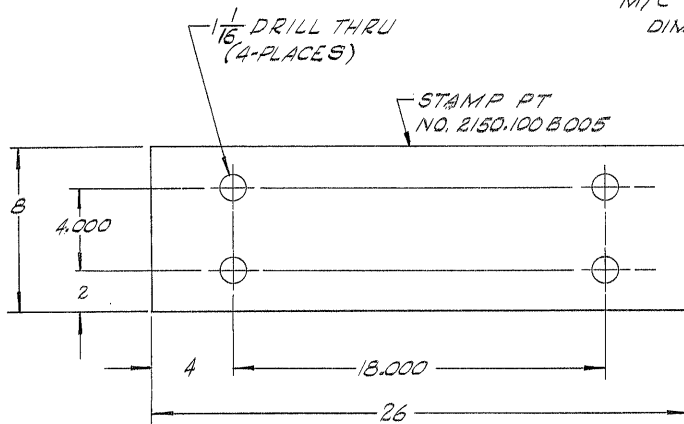
M/C TO FINAL
DIMENSION

NOTES:

1. ALL DIMENSIONS ARE IN INCHES
2. APPLY ONE COAT OF PRIME PAINT ALL OVER PER WG.C SPEC 511 IMMEDIATELY AFTER MACHINING.
3. MAT'L 8 x 1/2 x 26 STL ASTM A-36
4. STAMP PART NO. 2150.100 B005

WESTERN GEAR CORPORATION
CONSTRUCTION PROJECTS
DEPARTMENT
APPROVED FOR
PROCUREMENT

DATE 10/30/68

NEXT ASSY

2150.100E.002 (WGN 102845)
2150.101E.101 (WGN 102846)

REF. FILE 1153

LIMITS ON
MACHINED DIMENSIONS
EXCEPT AS NOTEDANGULAR $\pm 1^\circ 0'$

LINEAR

X = $\pm .1$ XX = $\pm .03$ XXX = $\pm .010$ FRACTIONAL $\pm 1/32$ BREAK ALL
SHARP EDGES150th STELLAR
TELESCOPE MOUNTINGDRAWN *Brooklyn*CHECK *GH*

ENGR

WGC 112728

APPROVED

WESTERN
GEAR CORPORATIONHEAVY MACHINERY DIVISION
EVERETT, WASHINGTONRA. SHOCK ABSORBER SHIM
BASE ASSYSIZE
BCODE IDENT NO.
16603

2150.100B005

REV
B

SCALE 1/4

WT. 30

LB SHEET 1 OF 1