

THIS DOCUMENT CONTAINS INFORMATION PROPRIETARY TO WESTERN GEAR CORPORATION. ALL DESIGN, MANUFACTURING, REPRODUCTION, USE, PATENT, AND SALES RIGHTS REGARDING THE SAME ARE HEREBY EXPRESSLY RESERVED BY WESTERN GEAR CORPORATION. THIS DOCUMENT IS SUBMITTED FOR REFERENCE PURPOSES ONLY AND SHALL NOT BE DISCLOSED TO ANY UNAUTHORIZED PERSON OR INCORPORATED INTO ANY OTHER PROJECT.

REVISIONS				
ZONE	LTR	DESCRIPTION	DATE	APPROVED
	A	ADDED CAP FOR DIAPHRAGM	7-6-71	LDS

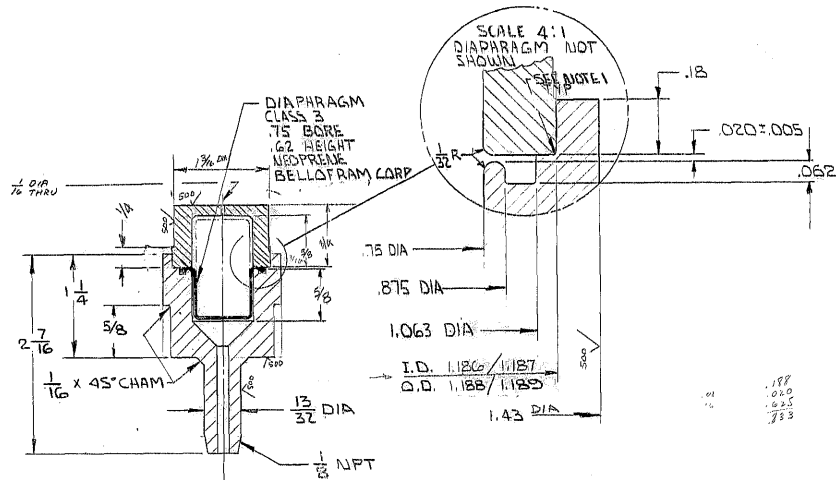

- NOTES.
1. MAX RADIUS OR CHAM. .02 E.A.N.
 2. MAT'L BRASS SAE #72 HALF HARD TEMPER
 3. FIN ¹²⁵ E.A.N

.188
.020
.025
.783

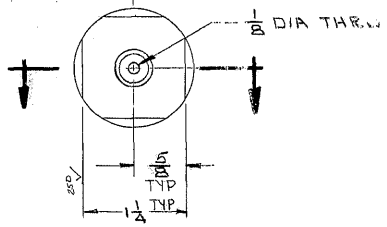

REF. 1152

NEXT FSSY 2150.005 C402

LIMITS ON MACHINED DIMENSIONS EXCEPT AS NOTED ANGULAR ± 1° 0' LINEAR X ± .1 XX ± .03 XXX ± .010 FRACTIONAL ± 1/32 BREAK ALL SHARP EDGES	DRAWN	LDS	WESTERN HEAVY MACHINERY DIVISION GEAR CORPORATION EVERET, WASHINGTON		
	CHECK		CLOSED SYSTEM BREATHER LAYOUT		
	ENGR	SKILES	SIZE	CODE IDENT NO.	REV
	APPROVED		B	16603	2150.005 B276
		SCALE FULL	WT.	LB	SHEET 1 OF 1