

REVISIONS				
ZONE	LTR	DESCRIPTION	DATE	APPROVED
	A	REVISED PER AURA APPD. CONST. PRINT DATED 6 MAY 68	7 MAY 68	
	B	ADDED OPTION & NOTE # 4	4/8/68	PG.
	C	REV NEXT ASSY NOS.	4/28/73	IDS

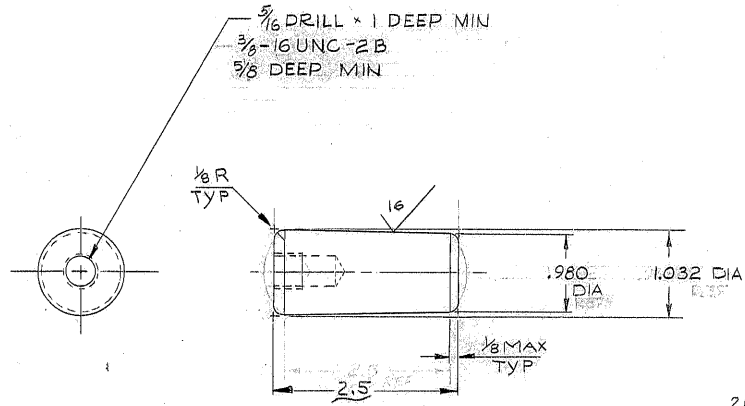

5/16 DRILL x 1 DEEP MIN
3/8 - 16 UNC - 2 B
3/8 DEEP MIN

1/8 R
TYP

1/8 MAX
TYP

NOTES:

- MATL: MAKE FROM STD ALLOY STEEL NO. 12
TAPER DOWEL PIN, 2 1/2" LONG.
OPTION: MANUFACTURE COMPLETE
USING AISI C1095 HT TO 350 BHN MIN.
OIL QUENCH FROM 1475°F, TEMPER AT 300°F.
- ALL DIMENSIONS IN INCHES.
- TAG PART NO. "2150.005 B 037"
- SMALL CENTERS ARE PERMISSIBLE

- 2150.101E002
2150.100E002
2150.280E002 (W.G.N 102844)
2150.202E-002 (W.G.N 103026)
2150.251E002 (W.G.N 102869)
2150.281E 102 (W.G.N 102948)
2150.215E002 (W.G.N 102 925)
2150.141E002 (W.G.N 102 871)
NEXT ASSY: 2150.140E002 (W.G.N. 102,870)

RET. FILE 1152

WESTERN GEAR CORPORATION
CONSTRUCTION PROJECTS
DEPARTMENT
APPROVED FOR
PROCUREMENT
JR DATE 5/1/68

LIMITS ON
MACHINED DIMENSIONS
EXCEPT AS NOTED
ANGULAR ± 1° 0'
LINEAR
X = ± .1
XX = ± .03
XXX = ± .010
FRACTIONAL ± 1/32
BREAK ALL
SHARP EDGES

150th STELLAR
TELESCOPE MTG.
DRAWN *R. M. S.*
CHECK *Gene Russo 21 FEB 68*
ENGR
WGC 112342
APPROVED

WESTERN GEAR CORPORATION HEAVY MACHINERY DIVISION
EVERETT, WASHINGTON
DOWEL, TAPER, NO. 12
SIZE **B** CODE IDENT NO. **16603** 2150.005B037
SCALE 1/1 WT. — LB SHEET 1 OF 1