

REVISIONS

ZONE	LTR	DESCRIPTION	DATE	APPROVED

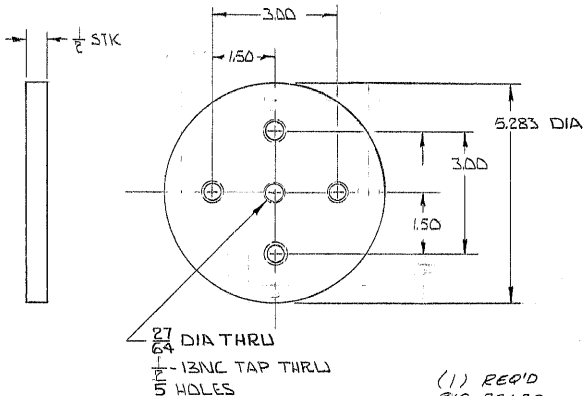

NOTES

1. SAND BLAST TO CLEAN UP
2. APPLY 1 COAT OF PRIME PAINT ALL OVER
3. STL STAMP P/W

NEXT ASSY

REF. FILE 1152

LIMITS ON MACHINED DIMENSIONS EXCEPT AS NOTED
 ANGULAR $\pm 1^{\circ} 0'$
 LINEAR
 X = $\pm .1$
 .XX = $\pm .03$
 .XXX = $\pm .010$
 FRACTIONAL $\pm 1/32$

MAT'L - STL
 1/2 x 5 3/8 DIA

WESTERN
 GEAR CORPORATION

HEAVY MACHINERY DIVISION
 EVERETT, WASHINGTON

DRAWN *G. Russo 5/16/72*

SPIDER, PULLER TANG
 FLIP BEARING
 150" TELE

CHECK

ENGR SKILES

A 302 305

SIZE A
 CODE IDENT NO. 16603

2150.005A311

REV -

APPROVED

BREAK ALL SHARP EDGES

SCALE 1/1 WT. LB SHEET 1 OF 1