

REVISIONS

WORK	LTR	DESCRIPTION	DATE	APPROVED

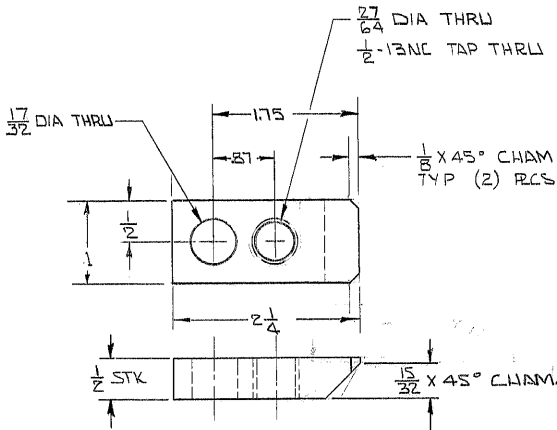

NOTES.

1. SAND BLAST TO CLEAN UP
2. APPLY (1) COAT OF PRIME PAINT
3. STL STAMP P/N

4 REO'S
918-32630

REF. FILE 1152

NEXT ASSY:

LIMITS ON MACHINED DIMENSIONS EXCEPT AS NOTED ANGULAR ± 1° 0' LINEAR X = ± .1 XX = ± .03 XXX = ± .010 FRACTIONAL ± 1/32 BREAK ALL SHARP EDGES	MAT'L <u>STL</u> 1/2 X 1 X 2 1/4	Western HEAVY MACHINERY DIVISION GEAR CORPORATION EVERETT, WASHINGTON	
	DRAWN <u>G. Russo 5/16/72</u>	TANG, PULLER FLIP BEARING - 150" TELE	
	CHECK	SIZE CODE IDENT NO. A 16603	
	ENGR <u>SKILES</u>	2150.005A310	REV -
APPROVED <u>A 302 304</u>	SCALE <u>1/1</u>	WT.	LB SHEET <u>1</u> OF <u>1</u>