

NOTES: UNLESS OTHERWISE NOTED

1. REMOVE ALL BURRS AND SHARP EDGES $.03$ R MAX

2. MACHINED SURFACE ROUGHNESS 125

3. MATERIAL: STAINLESS STEEL TYPE 203 E-Z CUT

REVISIONS					
LTR	DESCRIPTION	ECR	DATE	BY	APVD
A	REVISED DETAIL $\frac{1}{4}$ " TO SHOW TAPPED HOLE INSTEAD OF GROOVE 1.854 WAS 1.860		15662-1676	PLB	JK

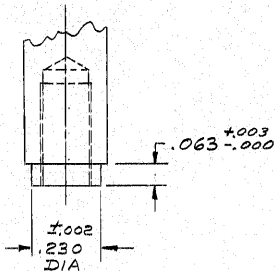
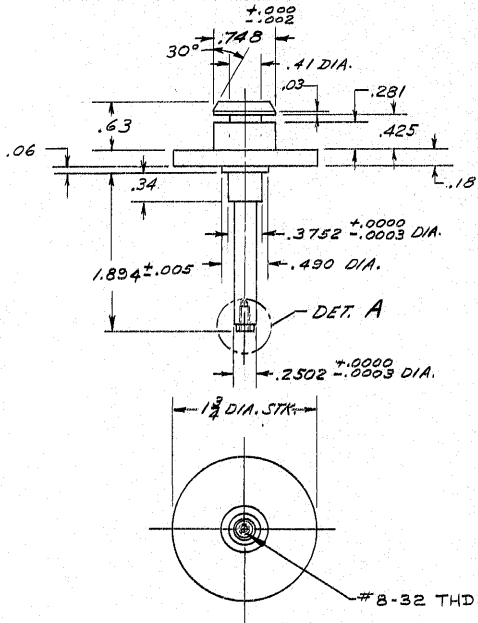

TOLERANCES UNLESS OTHERWISE NOTED				KITT PEAK NATIONAL OBSERVATORY			
DECIMALS	FRACTIONS	ANGULAR		OPERATED BY THE ASSOCIATION OF UNIVERSITIES FOR RESEARCH IN ASTRONOMY, INC. UNDER CONTRACT WITH NATIONAL SCIENCE FOUNDATION			
$.XX \pm .03$	$\frac{1}{16}$	$\pm 90^\circ$					
$.XXX \pm .010$							
NEXT ASSEMBLY 2131.028-61	NAME SHAFT-FILTER WHEEL	REF FILE 1311					
	150 TELESCOPE						
SCALE FULL	DESIGNED BY CWA	DATE 4/16/73	APPROVED BY M. HANEY	DATE 5/7/73	DWG NO. 2131.028-81	REV A	
PRINT ISSUED	DRAWN BY CWA	DATE 4/16/73	APPROVED BY	DATE			
	CHECKED BY KAC	DATE 5/16/73	APPROVED BY	DATE	RELEASE DATE 5-11-73		