

NOTES: UNLESS OTHERWISE SPECIFIED

1. REMOVE ALL BURRS AND SHARP EDGES .015
2. MACHINED SURFACE ROUGHNESS 125 ✓
3. MAT'L: BLACK DELRIN
4. FINISH: NONE

REVISIONS

| LTR | DESCRIPTION | ECR | DATE | BY | APRV |
|-----|-------------|-----|------|----|------|
|-----|-------------|-----|------|----|------|

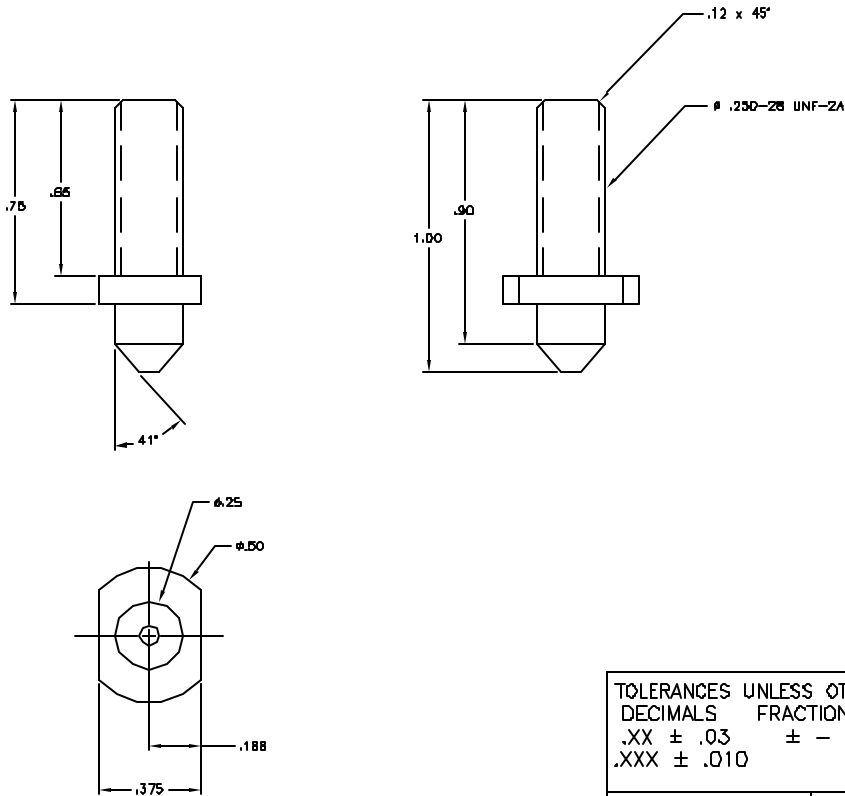

TOLERANCES UNLESS OTHERWISE NOTED  
 DECIMALS FRACTIONS ANGULAR  
 .XX ± .03 ± - ± 0°30'  
 .XXX ± .010

NATIONAL OPTICAL ASTRONOMY OBSERVATORIES  
 OPERATED BY THE  
 ASSOCIATION OF UNIVERSITIES FOR RESEARCH IN ASTRONOMY  
 UNDER COOPERATIVE AGREEMENT WITH  
 NATIONAL SCIENCE FOUNDATION

|  |                 |                               |             |      |                  |          |
|--|-----------------|-------------------------------|-------------|------|------------------|----------|
| NEXT ASSEMBLY<br>2131.003E53           |                 | NAME<br>PRISM ARM<br>STOP PIN |             |      | REF FILE<br>1301 |          |
|  |                 |                               |             |      | USED ON          |          |
| SCALE<br>4:1                           | DESIGNED BY     | DATE                          | APPROVED BY | DATE | DWG NO           | REV      |
| DRAWING PRODUCED USING<br>AUTOCAD v.14 | DRAWN BY<br>DPG | DATE<br>9/23/02               | APPROVED BY | DATE | 2131.003B28      |          |
| ISSUED                                 | CHECKED BY      | DATE                          | APPROVED BY | DATE |                  |          |
|  |                 |                               |             |      | RELEASED         | SHEET OF |