

ITEM	QTY	MATERIAL	DESCRIPTION
------	-----	----------	-------------

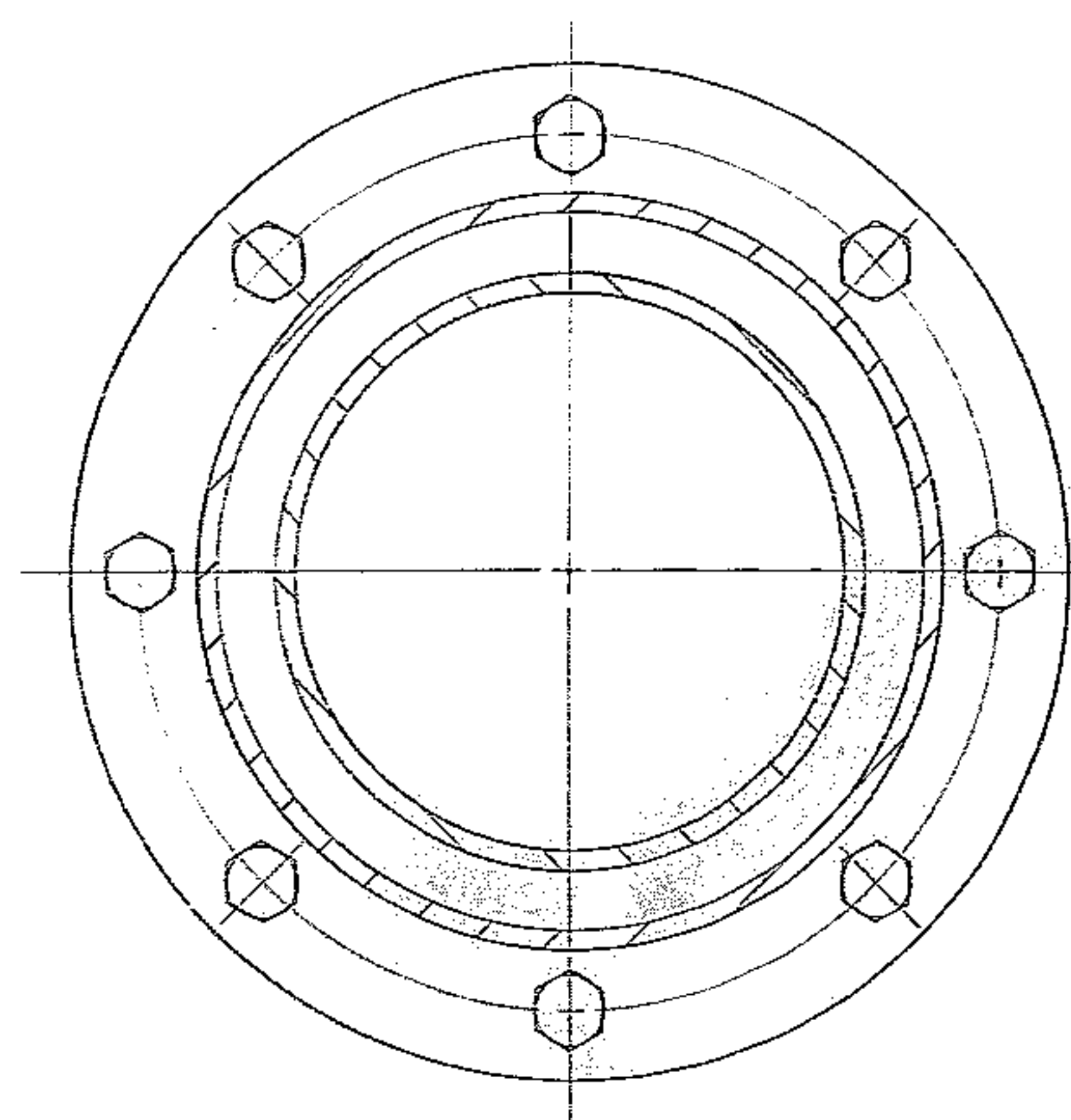

SECTION B-B
HALF SIZE

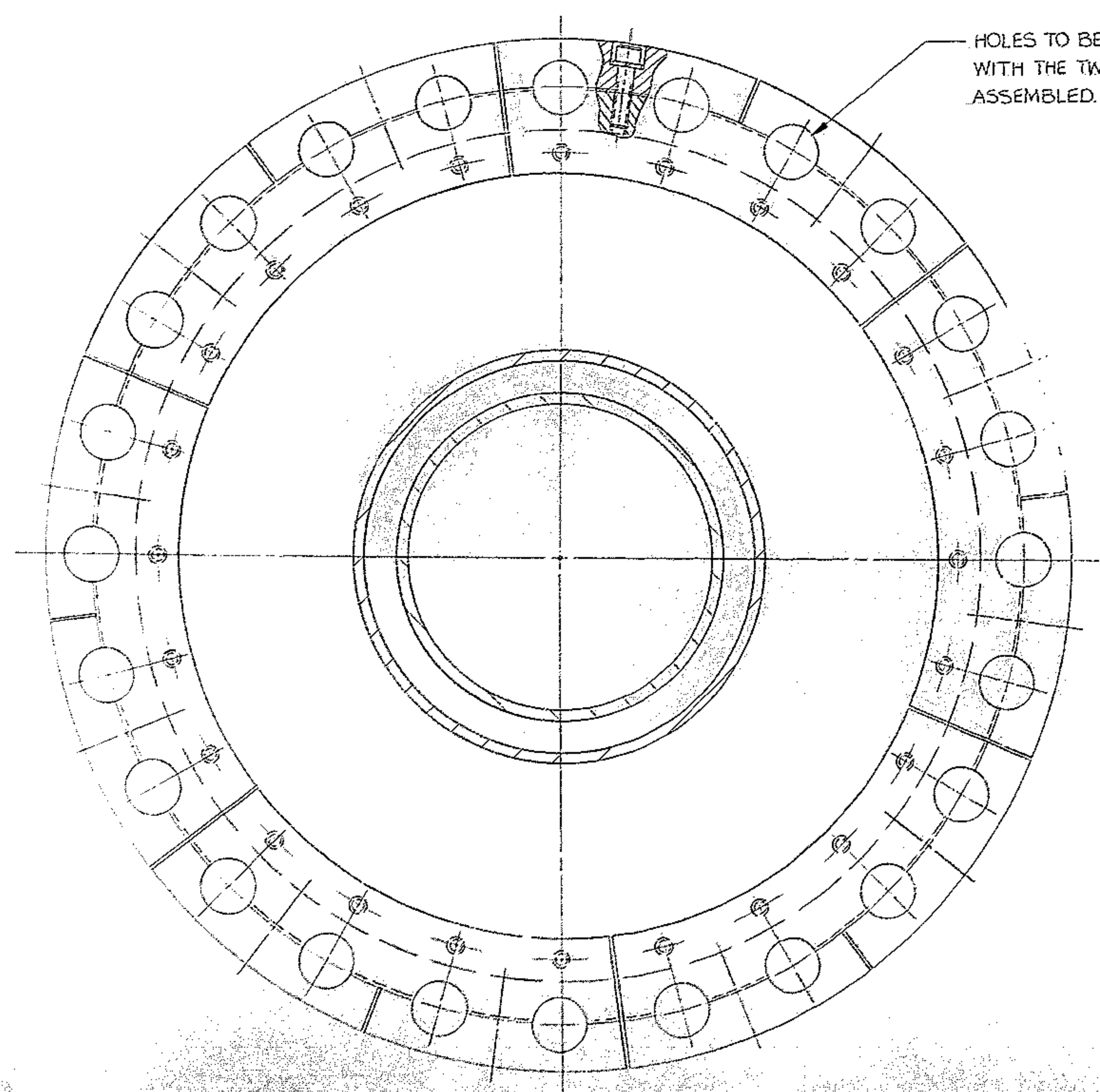

HOLES TO BE 1.250 DIA
WITH THE TWO RINGS
ASSEMBLED.

SECTION A-A
HALF SIZE

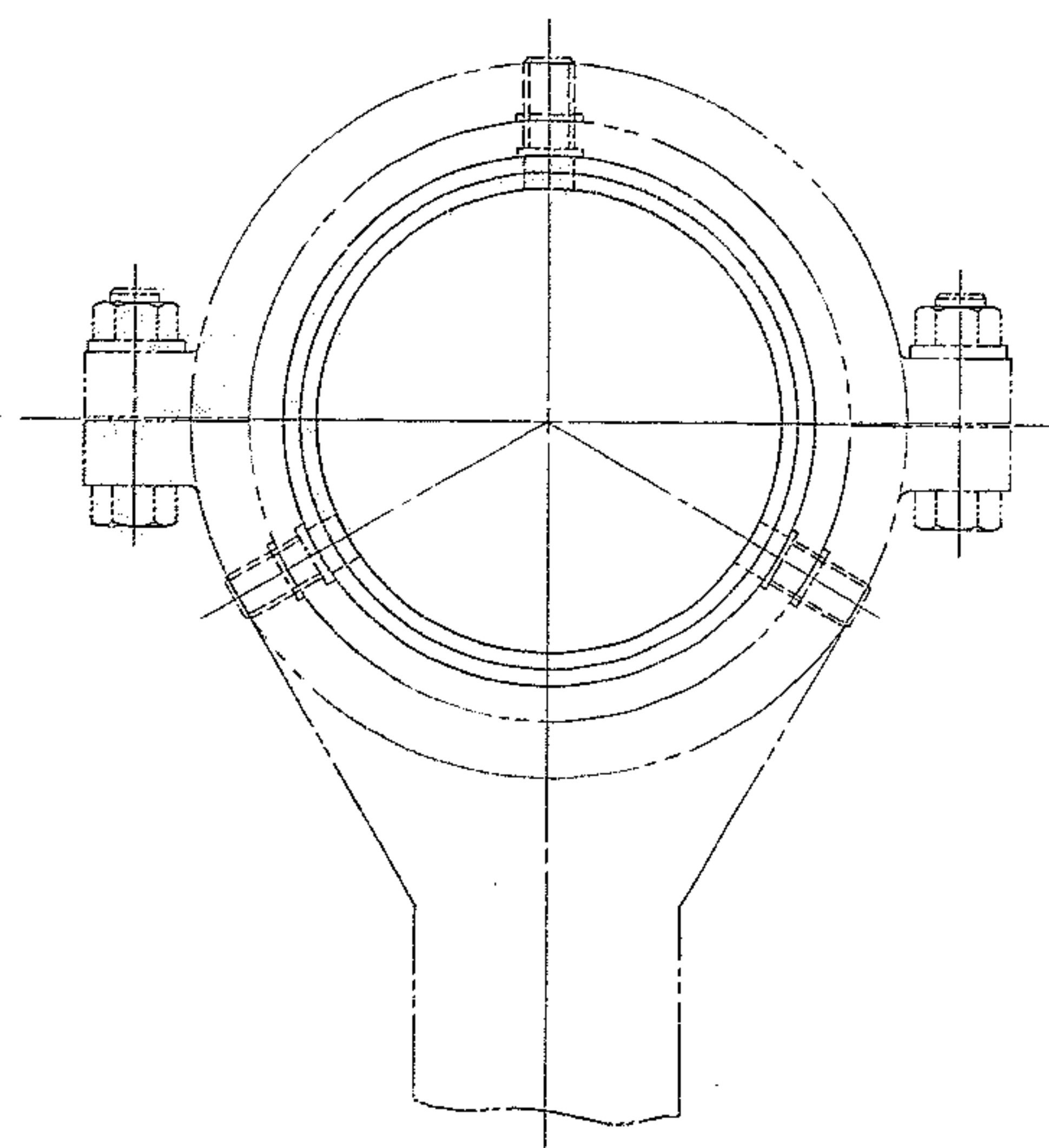

VIEW C-C
HALF SIZE

SEE SHEET #1 FOR
WESTERN GEAR CORP. DETAIL PART NOS.

FOR ASSEMBLY SEE

TOLERANCES
UNLESS OTHERWISE NOTED
DECIMAL DIMENSIONS
0.005 & 0.010
SHOULDER LOCUS
FRACTIONAL DIMENSIONS
UP TO 10" ± 1/64"
10" TO 50" ± 1/32"
50" & OVER ± 1/16"
BREAK SHARP EDGES
ALL SURFACES
TO HAVE V FINISH
UNLESS OTHERWISE NOTED.

KITT PEAK NATIONAL OBSERVATORY

ASSOCIATION OF UNIVERSITIES FOR RESEARCH IN ASTRONOMY, INC.
NATIONAL SCIENCE FOUNDATION

150" STELLAR TELESCOPE SHEET 1163

NAME LAYOUT OF REVISIONS TO
IMPROVE ASSEMBLY & SERVICE
OF P.A. CABLE WRAP-UP ASSEMBLY.

SCALE HALF
PRINT ISSUED

DESIGNED BY DATE APPROVED BY DATE
DRAWN BY DATE APPROVED BY DATE
CHECKED BY DATE APPROVED BY DATE

DRAWING NUMBER
2120-E41

REV.	DESCRIPTION	DATE	BY